

GOLD'S GYM®

◆ PLATINUM ◆

Model No. GGSY3058.0

Serial No. _____

Write the serial number in the space above for future reference.

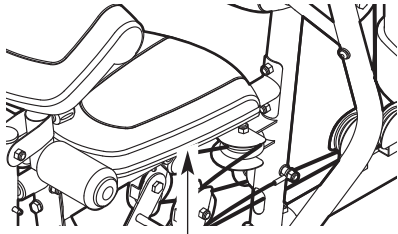

Serial Number Decal (under seat)

QUESTIONS?

As a manufacturer, we are committed to providing complete customer satisfaction. If you have questions, or if parts are damaged or missing, **PLEASE DO NOT CONTACT THE STORE;** please contact Customer Care.

IMPORTANT: You must note the product model number and serial number (see the drawing above) before contacting us:

CALL TOLL-FREE:

1-877-776-4777

Mon.–Fri. 6 a.m.–6 p.m. MST

Sat. 8 a.m.–4 p.m. MST

ON THE WEB:

www.goldsgympowerflex.com

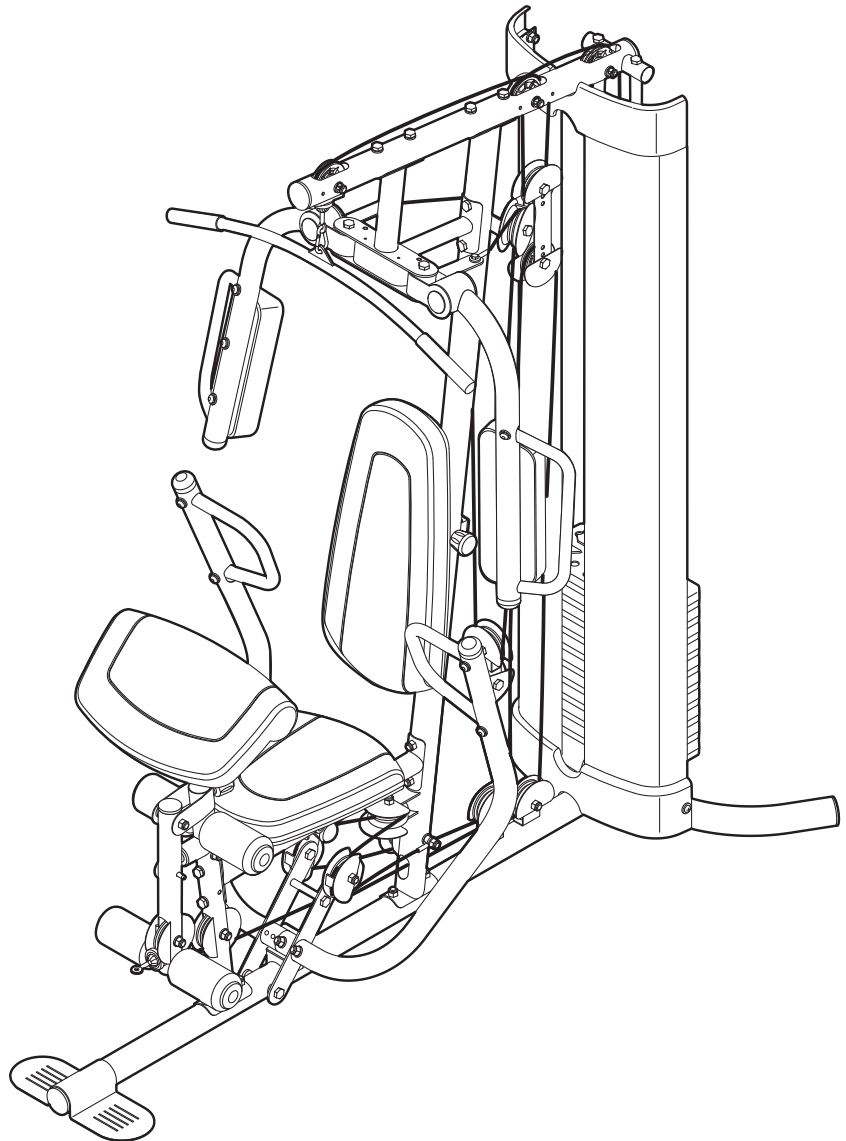

⚠ CAUTION

Read all precautions and instructions in this manual before using this equipment. Save this manual for future reference.

USER'S MANUAL

TABLE OF CONTENTS

WARNING DECAL PLACEMENT	2
IMPORTANT PRECAUTIONS	3
BEFORE YOU BEGIN	4
PART IDENTIFICATION CHART	5
ASSEMBLY	8
ADJUSTMENT	25
WEIGHT RESISTANCE CHART	27
CABLE DIAGRAM	28
MAINTENANCE	29
EXERCISE GUIDELINES	30
PART LIST	32
EXPLODED DRAWING	34
ORDERING REPLACEMENT PARTS	Back Cover
LIMITED WARRANTY	Back Cover

WARNING DECAL PLACEMENT

The warning decals shown here have been applied in the locations shown. **If a decal is missing or illegible, call the telephone number on the front cover of this manual and request a free replacement decal. Apply the decal in the location shown.** Note: The decals may not be shown at actual size.

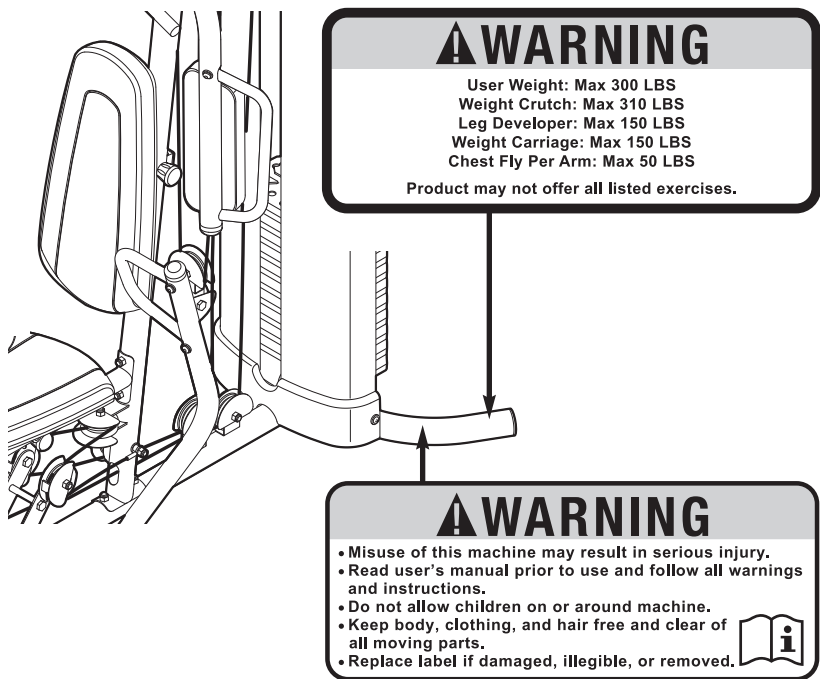

IMPORTANT PRECAUTIONS

⚠️ WARNING: To reduce the risk of serious injury, read all important precautions and instructions in this manual and all warnings on the weight system before using the weight system. ICON assumes no responsibility for personal injury or property damage sustained by or through the use of this product.

1. Before beginning any exercise program, consult your physician. This is especially important for persons over the age of 35 or persons with pre-existing health problems.
2. Use the weight system only as described in this manual.
3. It is the responsibility of the owner to ensure that all users of the weight system are adequately informed of all precautions.
4. The weight system is intended for home use only. Do not use the weight system in any commercial, rental, or institutional setting.
5. Keep the weight system indoors, away from moisture and dust. Place the weight system on a level surface, with a mat beneath it to protect the floor or carpet. Make sure that there is enough clearance around the weight system to mount, dismount, and use the weight system.
6. Inspect and properly tighten all parts regularly. Replace any worn parts immediately.
7. Keep hands and feet away from moving parts.
8. Keep children under age 12 and pets away from the weight system at all times.
9. Wear athletic shoes for foot protection while exercising.
10. Make sure that the cables remain on the pulleys at all times. If a cable binds while you are exercising, stop immediately and make sure that the cable is on the pulleys. Replace all cables at least every two years.
11. The weight system is designed to be used only with the included weight. Do not use the weight system with dumbbells or any other type of weight to increase the resistance.
12. The weight system should not be used by persons weighing more than 300 lbs. (136 kg).
13. Make sure that the weight pin is inserted fully into the weight stack before you exercise.
14. If you feel pain or dizziness while exercising, stop immediately and cool down.

BEFORE YOU BEGIN

Thank you for selecting the versatile GOLD'S GYM® PLATINUM weight system. The weight system offers a selection of exercise stations designed to develop every major muscle group of the body. Whether your goal is to tone your body, build dramatic muscle size and strength, or improve your cardiovascular system, the weight system will help you to achieve the specific results you want.

For your benefit, read this manual carefully before using the weight system. If you have questions after reading this manual, please see the front cover of this

manual. To help us assist you, note the product model number and serial number before contacting us. The model number and the location of the serial number decal are shown on the front cover of this manual.

To avoid a registration fee for any service needed under warranty, you must register the weight system at www.iconservice.com/registration.

Before reading further, please review the drawing below and familiarize yourself with the parts that are labeled.

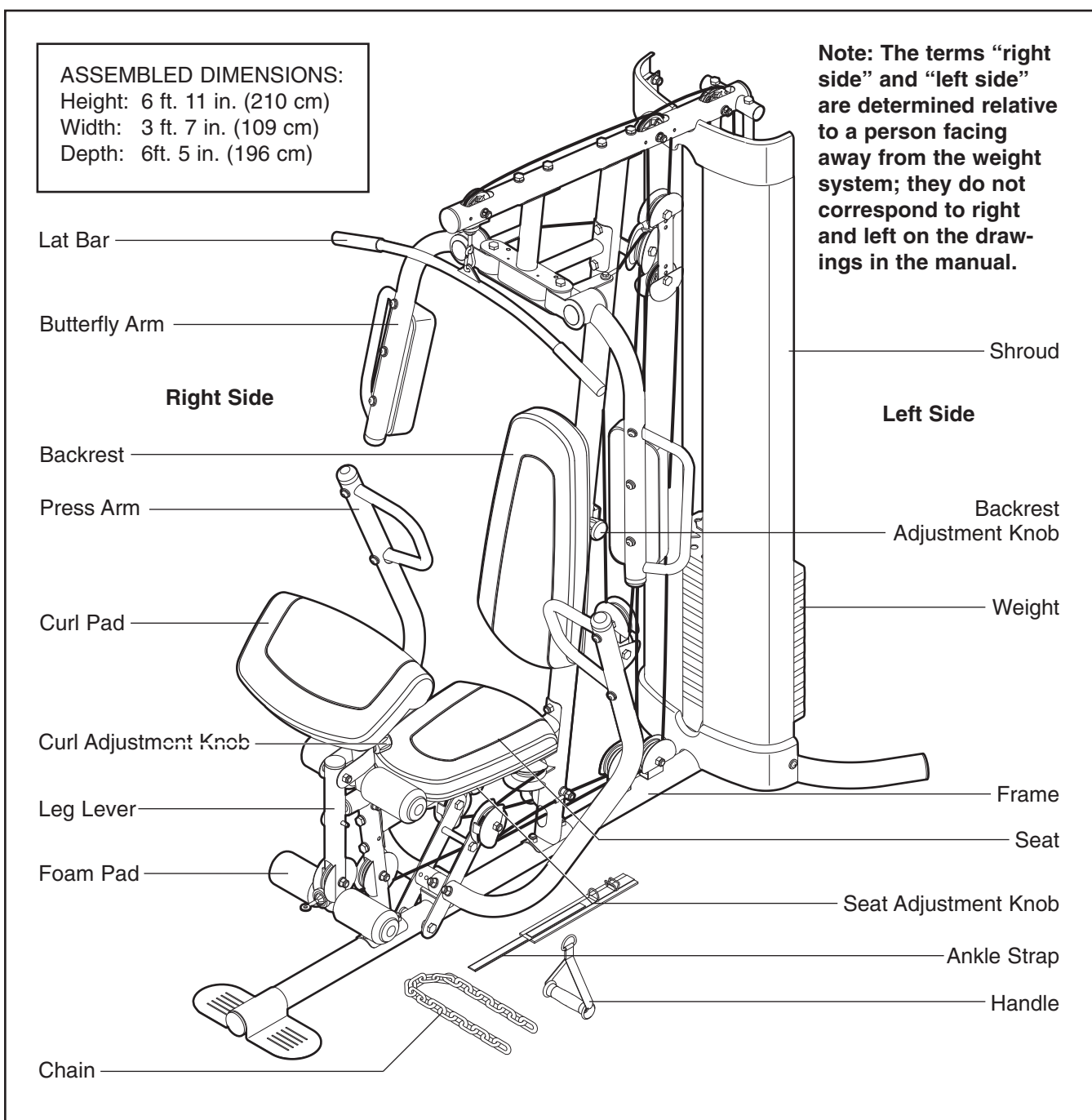

PART IDENTIFICATION CHART

Refer to the drawings below to identify small parts used in assembly. The number in parentheses by each drawing is the key number of the part, from the PART LIST near the end of this manual. **Note: Some small parts may have been preattached. If a part is not in the hardware kit, check to see if it has been preattached.**

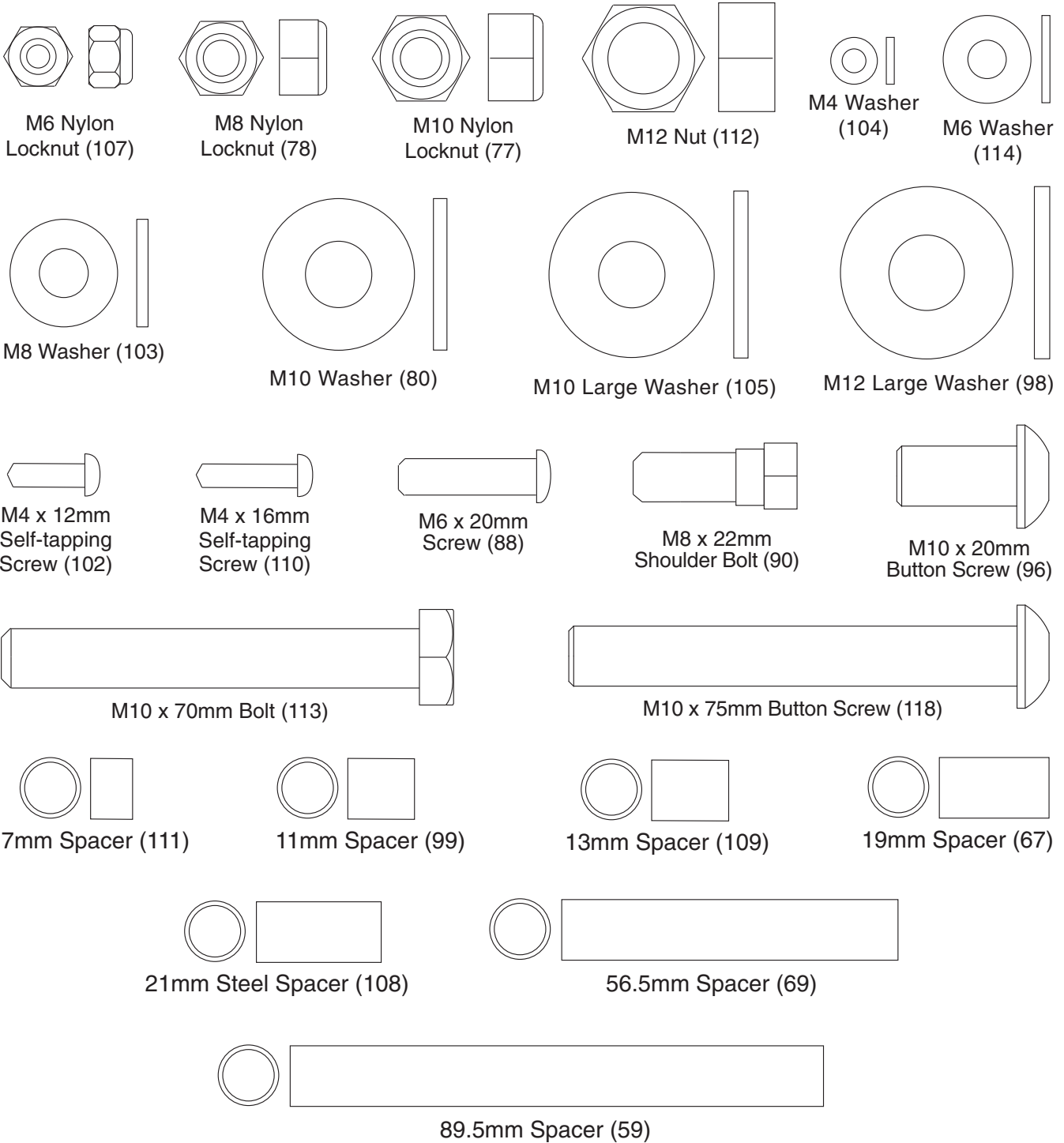



M8 x 69mm Shoulder Bolt (87)

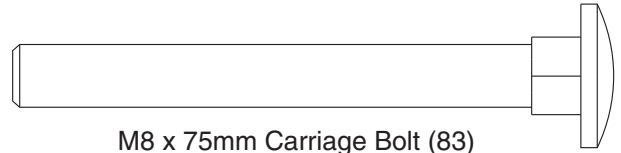

M8 x 75mm Carriage Bolt (83)

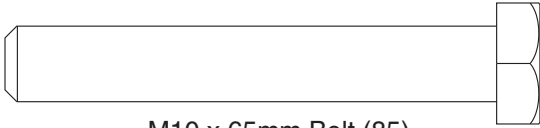

M10 x 65mm Bolt (85)

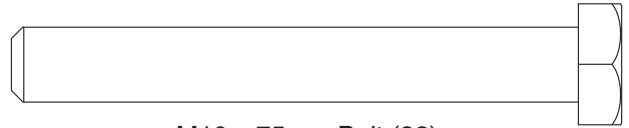

M10 x 75mm Bolt (82)



M8 x 65mm Bolt (101)

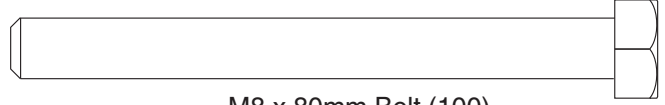

M8 x 80mm Bolt (100)

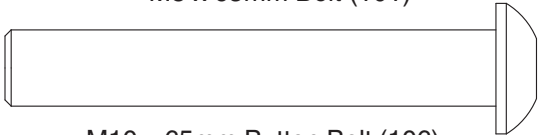

M10 x 65mm Button Bolt (106)

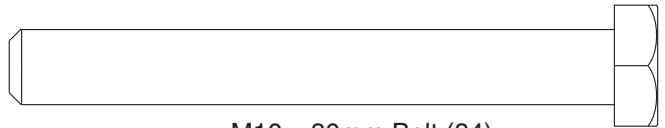

M10 x 80mm Bolt (84)



M6 x 65mm Button Screw (91)

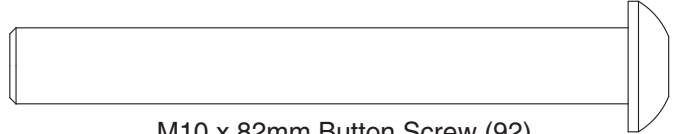

M10 x 82mm Button Screw (92)



M10 x 60mm Bolt (79)

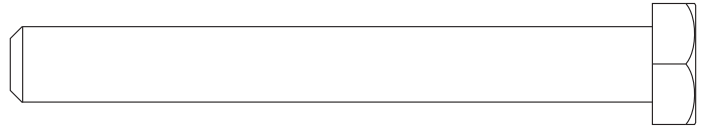

M10 x 85mm Bolt (81)

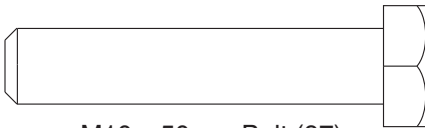

M10 x 50mm Bolt (97)

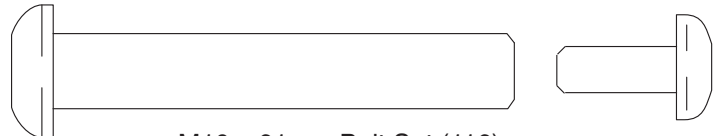

M10 x 61mm Bolt Set (116)

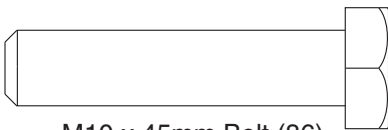

M10 x 45mm Bolt (86)

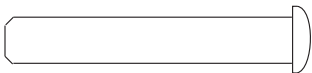

M6 x 38mm Screw (89)

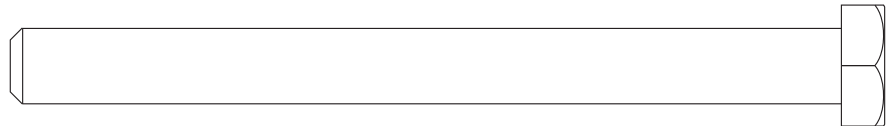

M10 x 110mm Bolt (93)



M6 x 28mm Bolt (94)

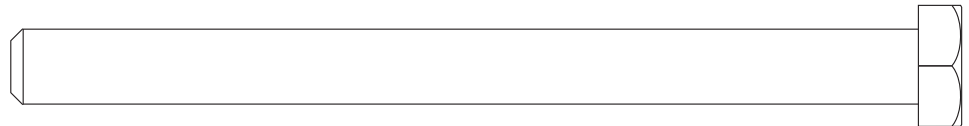

M10 x 120mm Bolt (115)

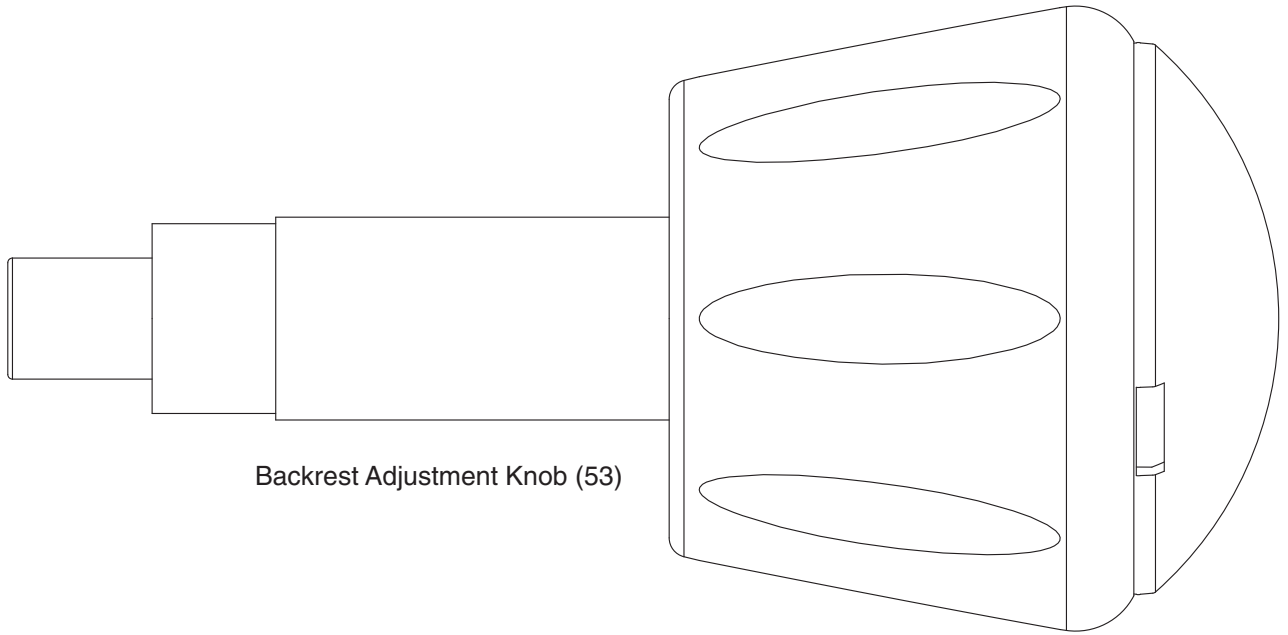

Backrest Adjustment Knob (53)

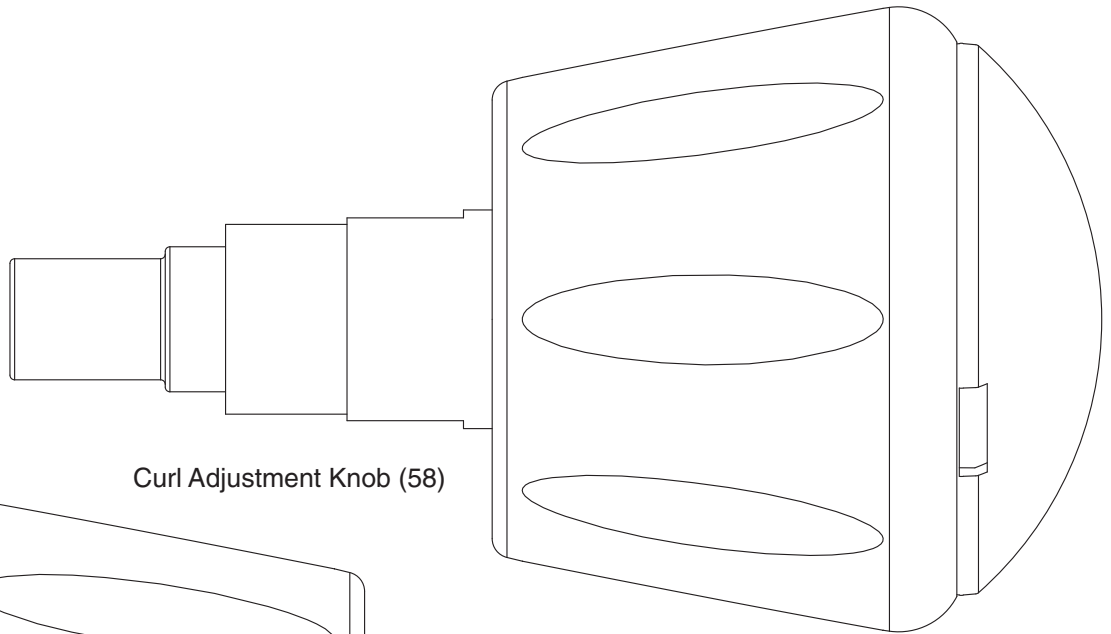

Curl Adjustment Knob (58)

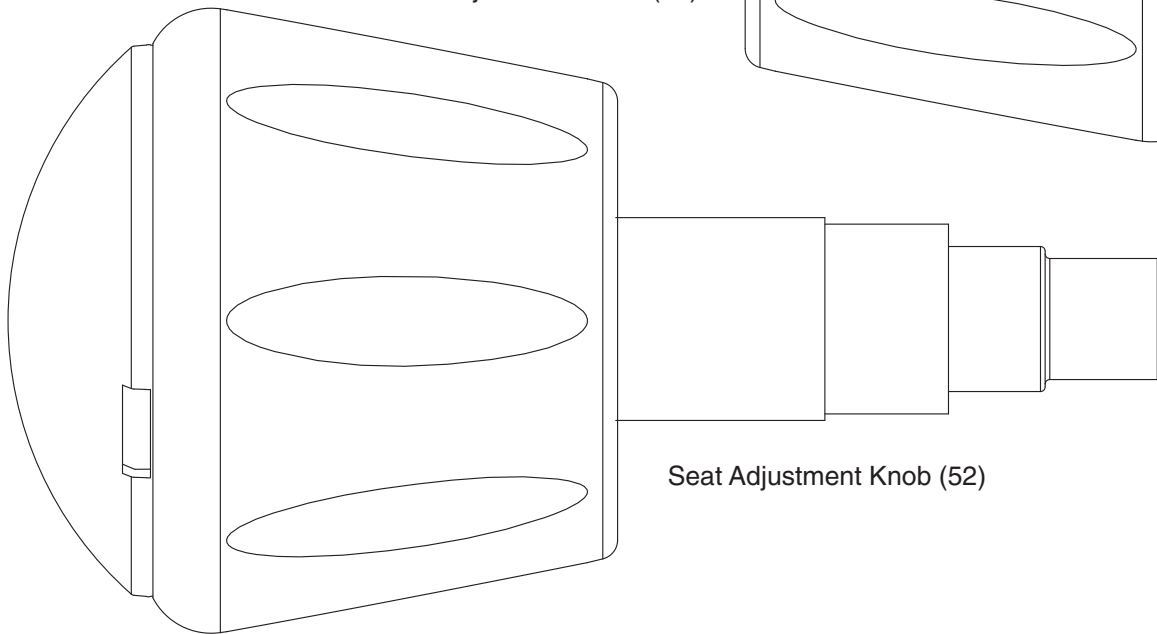

Seat Adjustment Knob (52)

ASSEMBLY

Make Assembly Easier

Everything in this manual is designed to ensure that the weight system can be assembled successfully by almost anyone. By setting aside plenty of time, assembly will go smoothly.

Before beginning assembly, carefully read the following information and instructions:

- To hire an authorized service technician to assemble the weight system in your home, call 1-800-445-2480.
- Assembly requires two persons.
- Because of its weight and size, the weight system should be assembled in the location where it will be used. Make sure that there is enough clearance to walk around the weight system as you assemble it.
- To make assembly as easy as possible, we have divided the assembly process into four stages. The parts needed for each stage are found in individual hardware kits. Place all parts of the weight system in a cleared area and remove the packing materials. Do not dispose of the packing materials until assembly is completed.

- Place all parts in a cleared area and remove the packing materials. Do not dispose of the packing materials until assembly is completed.
- For help identifying small parts, use the PART IDENTIFICATION CHART on pages 5–7.
- As you assemble the weight system, make sure that all parts are oriented as shown in the drawings.
- Tighten all parts as you assemble them, unless instructed to do otherwise.
- Assembly requires the included hex key and grease and the following tools (not included):

Two adjustable wrenches 

One rubber mallet 

One standard screwdriver 

One Phillips screwdriver 

Assembly will be more convenient if you have a socket set, a set of open-end or closed-end wrenches, or a set of ratchet wrenches.

The Four Stages of the Assembly Process

Frame Assembly—You will begin by assembling the base and the uprights that form the skeleton of the weight system.

Arm Assembly—During this stage you will assemble the arms and the leg lever.

Cable Assembly—During this stage you will attach the cables and pulleys that connect the arms to the weights.

Seat Assembly—During the final stage you will assemble the seat and the backrest.

Frame Assembly

1. Before beginning assembly, make sure that you understand the information in the box on page 8. See the **PART IDENTIFICATION CHARTS** on pages 5–7 for help identifying small parts.

Insert four M8 x 75mm Carriage Bolts (83) up into the Base (1). **Note: It may be helpful to place a piece of tape over each bolt head to hold it in place.**

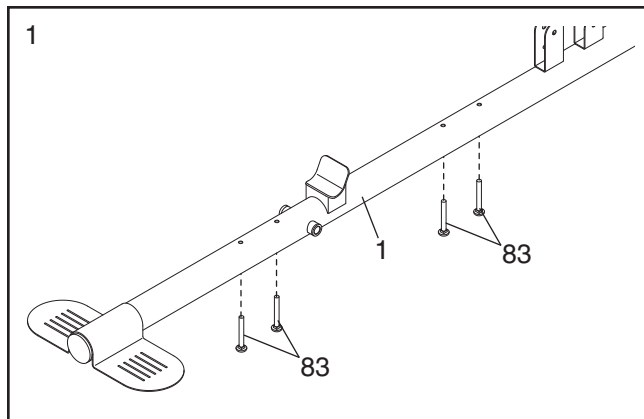

2. Insert the two Weight Guides (18) into the Stabilizer (3). **Make sure that the indicated holes in the Weight Guides are nearer the floor.**

Attach the Stabilizer (3) and the Weight Guides (18) to the Base (1) with two M10 x 85mm Bolts (81), two M10 Washers (80), two 21mm Steel Spacers (108), and two M10 Nylon Locknuts (77). **Do not tighten the Nylon Locknuts yet.**

Next, attach the Weight Guides (18) to the Stabilizer (3) with two M10 x 20mm Button Screws (96). Then, attach the Stabilizer to the Base (1) with an M8 x 75mm Carriage Bolt (83) and an M8 Nylon Locknut (78). **Do not tighten the Nylon Locknut yet.**

Attach the Upright (2) to the Base (1) with the two indicated M8 x 75mm Carriage Bolts (83) and two M8 Nylon Locknuts (78). **Do not tighten the Nylon Locknuts yet.**

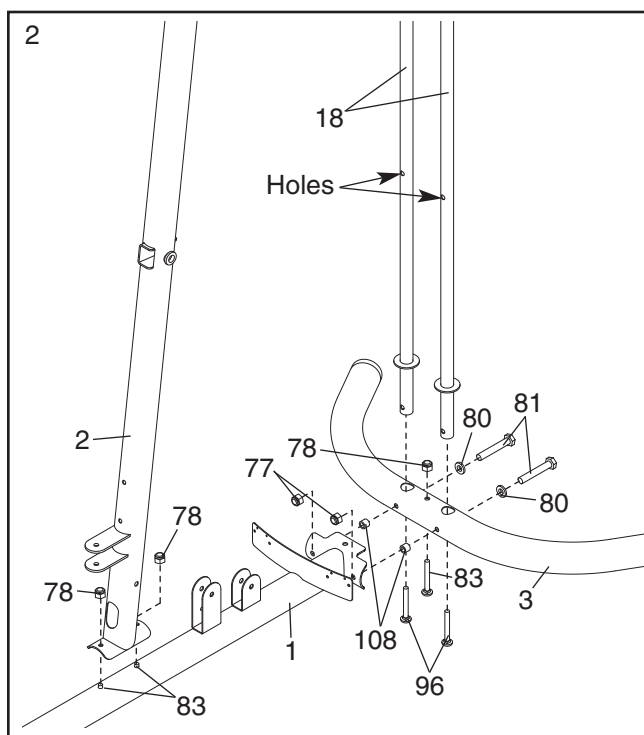

3. Attach the Front Leg (10) to the Base (1) with the two M8 x 75mm Carriage Bolts (83) and two M8 Nylon Locknuts (78). **Do not tighten the Nylon Locknuts yet.**

Attach the Leg Lever Bumper (75) to the Front Leg (10) with an M4 x 16mm Self-tapping Screw (110) and an M4 Washer (104). **Make sure that the end of the Leg Lever Bumper is pointing up.**

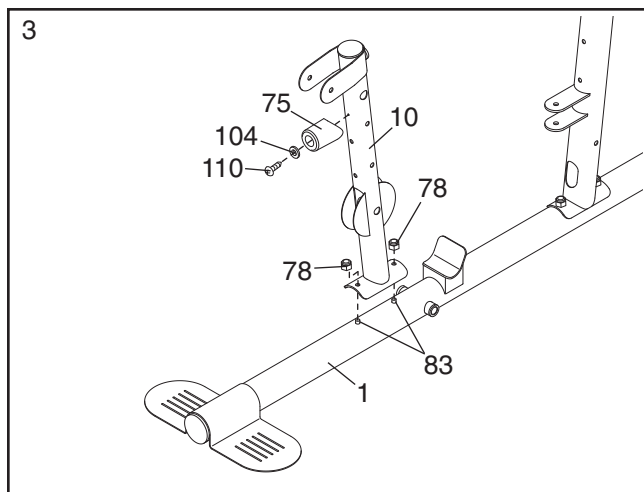

- Attach the Top Frame (4) to the Upright (2) with two M8 x 80mm Bolts (100), two M8 Washers (103), and two M8 Nylon Locknuts (78). **Do not tighten the Nylon Locknuts yet.**

Attach the Weight Guides (18) to the Top Frame (4) with two M10 x 20mm Button Screws (96) and two M10 Washers (80).

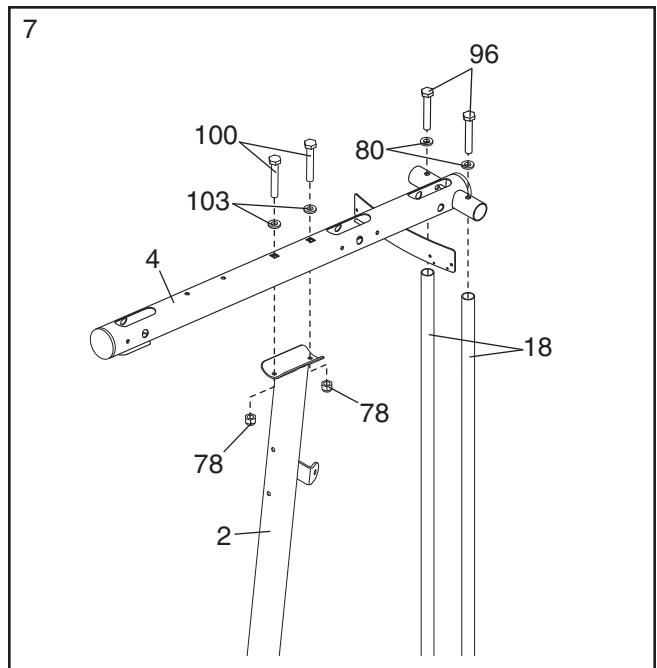

- Attach the top of the Left Shroud (21) to the Top Frame (4) with two M4 x 12mm Self-tapping Screws (102).

Repeat this step for the Right Shroud (22).

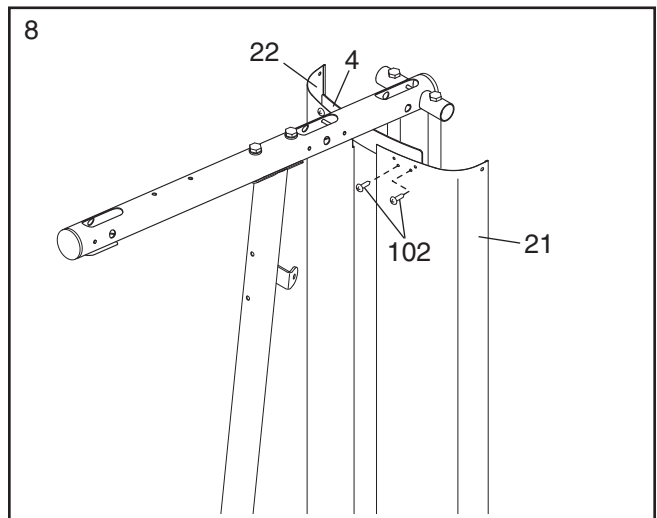

- Attach a Shroud Cover (23) to the Left and Right Shrouds (21, 22) with two M6 x 28mm Bolts (94), four M6 Washers (114), and two M6 Nylon Locknuts (107).

Attach the Shroud Cover (23) to the Top Frame (4) with four M4 x 16mm Self-tapping Screws (110) and four M4 Washers (104).

See the inset drawing and attach the other Shroud Cover (23) in the same way.

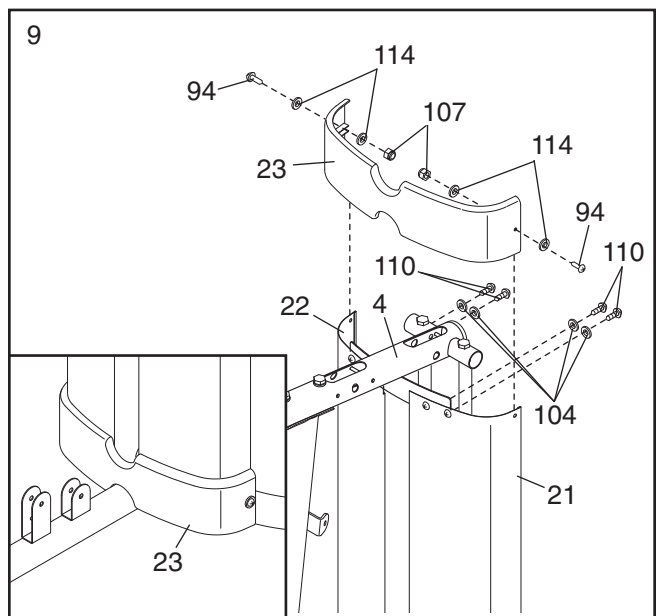

Arm Assembly

10. Attach the Butterfly Frame Brace (6) to the Upright (2) with two M8 x 80mm Bolts (100), two M8 Washers (103), and two M8 Nylon Locknuts (78). **Do not tighten the Nylon Locknuts yet.**

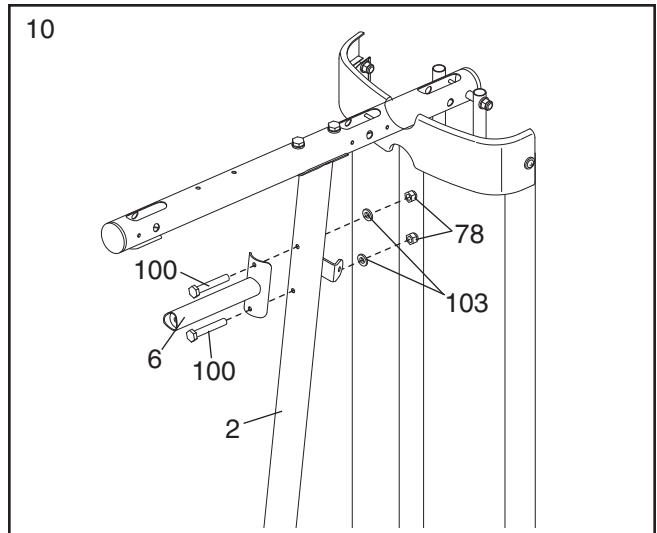

11. Apply a small amount of the included grease in the locations shown. Insert a 56.5mm Spacer (69) into the indicated hole in the Leg Lever (12). Attach the Leg Lever to the Front Leg (10) with an M10 x 61mm Bolt Set (116). **Make sure that the barrel of the Bolt Set is inserted through both sides of the bracket on the Front Leg. Make sure that the indicated rod is oriented as shown.**

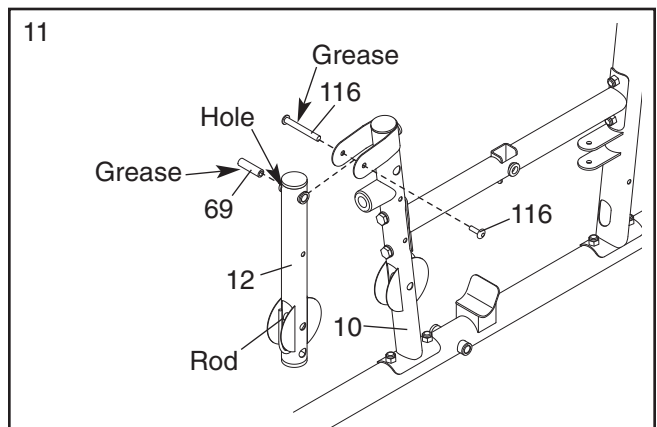

See the left inset drawing. Attach the Lock Plate (14) to the Front Leg (10) with the M8 x 69mm Shoulder Bolt (87), an M8 Washer (103), and an M8 Nylon Locknut (78).

See the right inset drawing. Insert the Lock Plate Pin (95) through the Lock Plate (14) and the Leg Lever (12). Attach the tether on the Lock Plate Pin to the Front Leg (10) with an M4 x 12mm Self-tapping Screw (102).

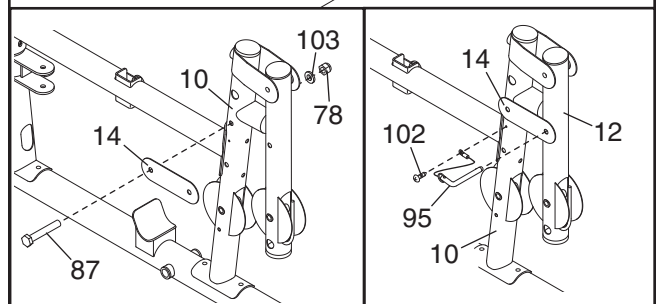

12. Attach the Butterfly Frame (5) to the Top Frame (4) with two M8 x 80mm Bolts (100), two M8 Washers (103), and two M8 Nylon Locknuts (78). **Do not tighten the Nylon Locknuts yet.**

Attach the Butterfly Frame (5) to the Butterfly Frame Brace (6) with an M10 x 75mm Button Screw (118).

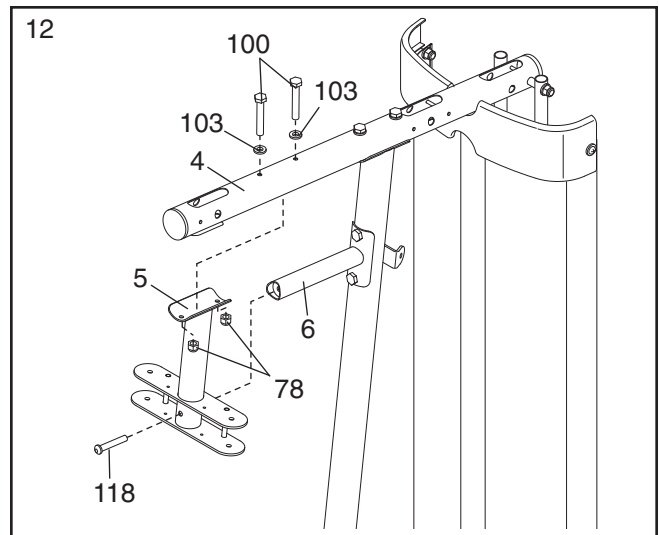

13. Grease to the locations shown and attach the Left Butterfly Bracket (28) to the Butterfly Frame (5) with an M10 x 80mm Bolt (84) and an M10 Nylon Locknut (77).

Repeat this step for the Right Butterfly Bracket (29).

See steps 2–13. Tighten the Nylon Locknuts (77, 78, 107).

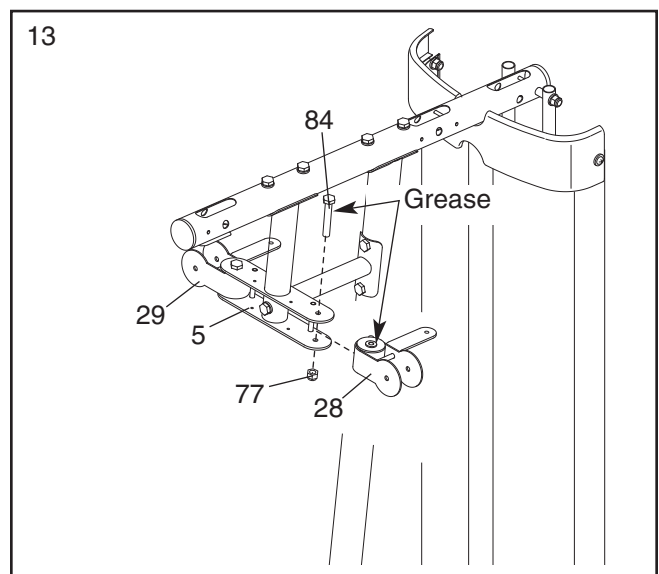

14. Attach a Butterfly Handle (27) to the Left Butterfly Arm (25) with an M10 x 65mm Button Bolt (106), two M10 Washers (80), two 13mm Steel Spacers (109), and an M10 Nylon Locknut (77).

Secure the Left Butterfly Arm (25) with an M10 x 82mm Button Screw (92) and an M10 Large Washer (105).

Repeat this step for the Right Butterfly Arm and Butterfly Handle (26, 27).

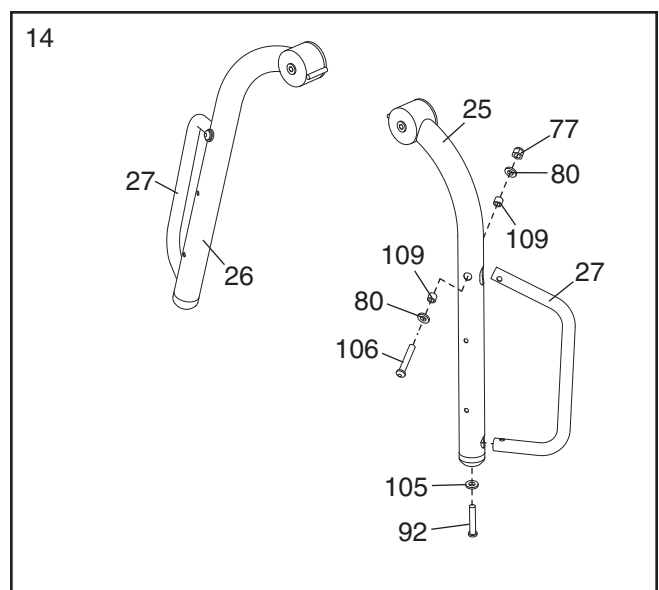

15. Grease in the locations shown and attach the Right Butterfly Arm (26) to the Right Butterfly Bracket (29) with an M10 x 75mm Bolt (82) and an M10 Nylon Locknut (77). Press a Bolt Cap (44) onto the end of the Bolt. **Do not overtighten the Bolt; the Butterfly Arm must pivot easily.**

Repeat this step for the Left Butterfly Arm (25).

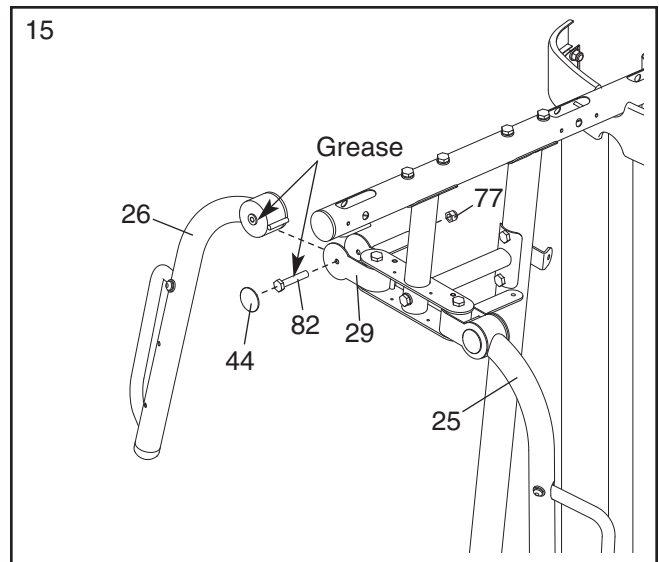

16. Orient a Press Arm Handle (17) with the 90° bend at the top as shown in the inset drawing. Attach a Press Arm Handle (17) to the Right Press Arm (16) with two M10 x 65mm Button Bolts (106), four M10 Washers (80), four 11mm Spacers (99), and two M10 Nylon Locknuts (77).

Repeat this step for the Left Press Arm (not shown).

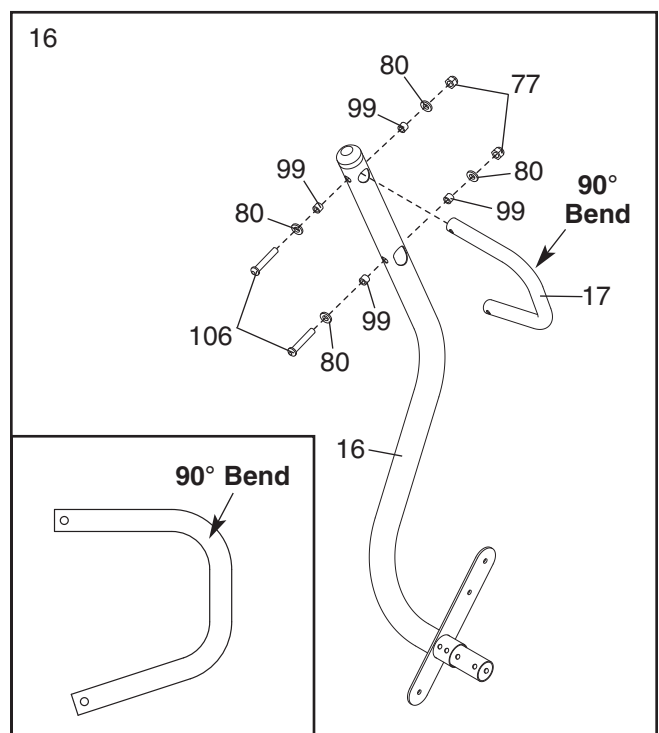

17. Attach the Left Press Arm (15) to the Right Press Arm (16) with an M10 x 110mm Bolt (93), an 89.5mm Spacer (59) and an M10 Nylon Locknut (77).

Finish attaching the Press Arms with two M10 x 65mm Bolts (85), two M10 Washers (80), and two M10 Nylon Locknuts (77). **Do not tighten the Nylon Locknuts yet.**

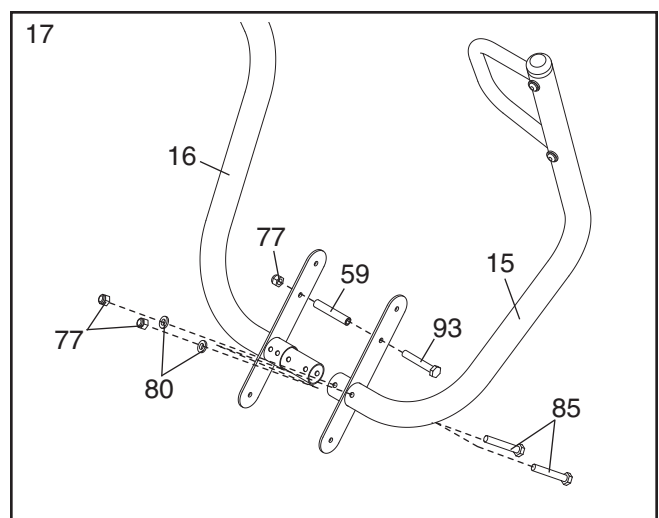

18. Apply grease in the locations shown and attach the Left and Right Press Arms (15, 16) to the Base (1) with an M10 x 110mm Bolt (93), an 89.5mm Spacer (59), and an M10 Nylon Locknut (77). **Do not over tighten the Nylon Locknut; the Press Arms must pivot easily.**

See step 17. Tighten the M10 Nylon Locknuts (77).

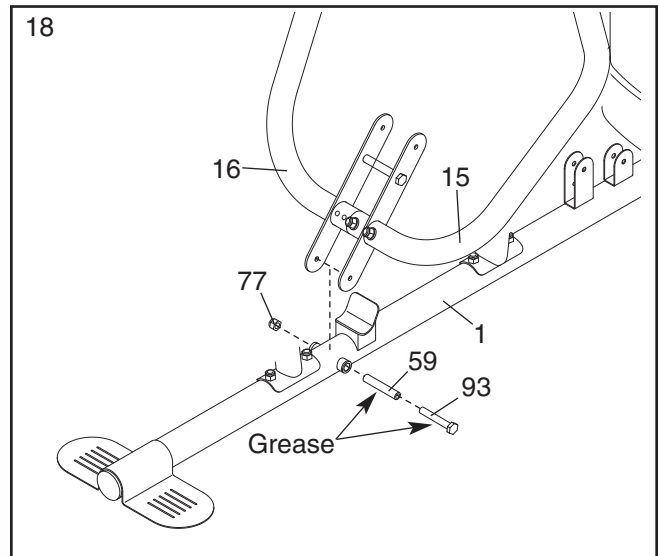

Cable Assembly

19. See the **CABLE DIAGRAMS** on page 28 to identify the cables as you assemble them.

Identify the Butterfly Cable (50). Grease an M8 x 22mm Shoulder Bolt (90). Attach the Cable to the Left Butterfly Bracket (28) with the Shoulder Bolt and an M8 Nylon Locknut (78). **See the inset drawing. Make sure that the flat edge of the Cable is against the Left Butterfly Arm. Do not overtighten the Shoulder Bolt; the Cable must pivot easily.**

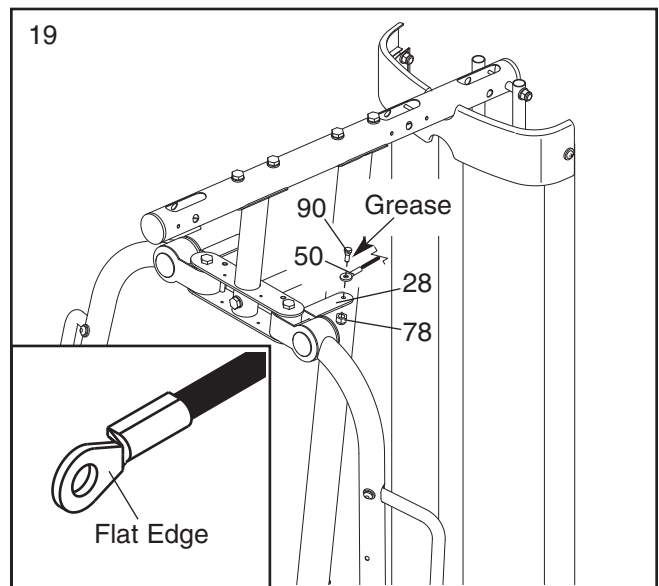

20. Wrap the Butterfly Cable (50) over a "V"-pulley (47). Attach the "V"-pulley, a Long Cable Trap (57), an M10 Washer (80), and two Guards (54) to the Upright (2) with an M10 x 60mm Bolt (79) and an M10 Nylon Locknut (77).

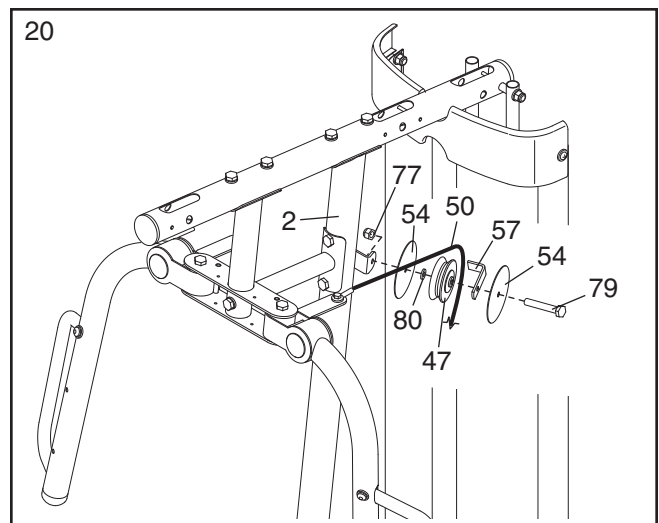

21. Wrap the Butterfly Cable (50) under a 90mm Pulley (48). Attach the Pulley and two Half Guards (55) to the Double "U"-bracket (61) with an M10 x 45mm Bolt (86) and an M10 Nylon Locknut (77). **Make sure that the Half Guards are oriented as shown.**

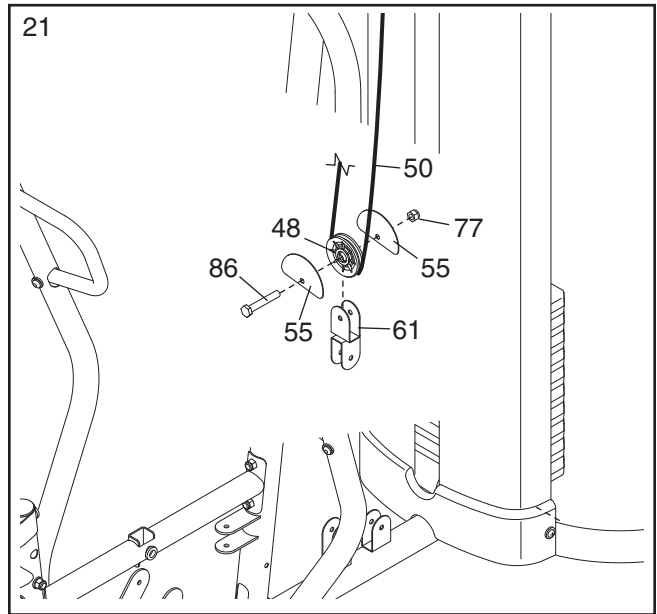

22. Wrap the Butterfly Cable (50) over a "V"-pulley (47). Attach the "V"-pulley, a Long Cable Trap (57), an M10 Washer (80), and two Guards (54) to the Upright (2) with an M10 x 60mm Bolt (79) and an M10 Nylon Locknut (77).

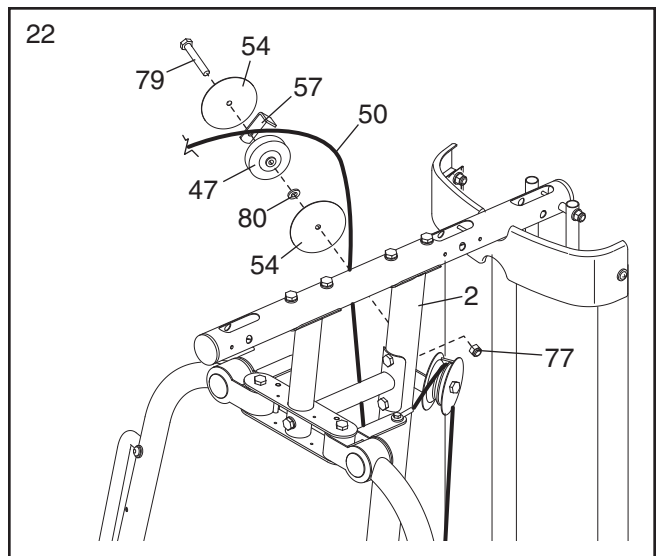

23. Grease an M8 x 22mm Shoulder Bolt (90). Attach the Butterfly Cable (50) to the Right Butterfly Arm (29) with the Shoulder Bolt and an M8 Nylon Locknut (78). **See the inset drawing. Make sure that the flat edge of the Cable is against the Right Butterfly Arm.**

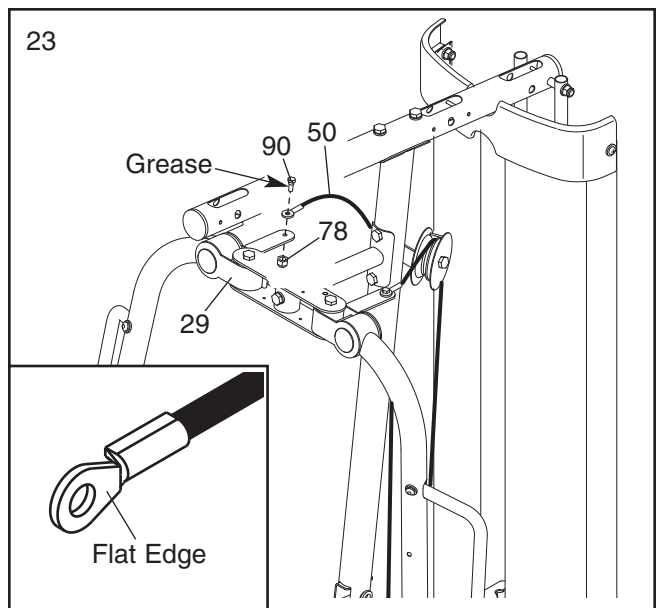

24. **Identify the Lat Cable (49).** Route the Cable up through the Top Frame (4) and over a 90mm Pulley (48). Attach the Pulley inside the Top Frame with an M10 x 80mm Bolt (84), two M10 Washers (80), two 19mm Spacers (67), and an M10 Nylon Locknut (77).

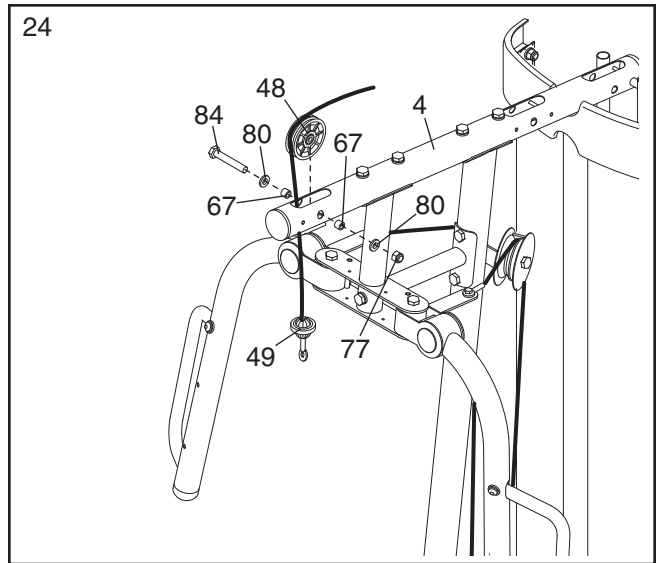

25. Route the Lat Cable (49) over a Thin Pulley (24) and down through the Top Frame (4). Hold the Thin Pulley inside the Top Frame. Insert an M10 x 80mm Bolt (84) through an M10 Washer (80), a 19mm Spacer (67), the Top Frame, and the Thin Pulley.

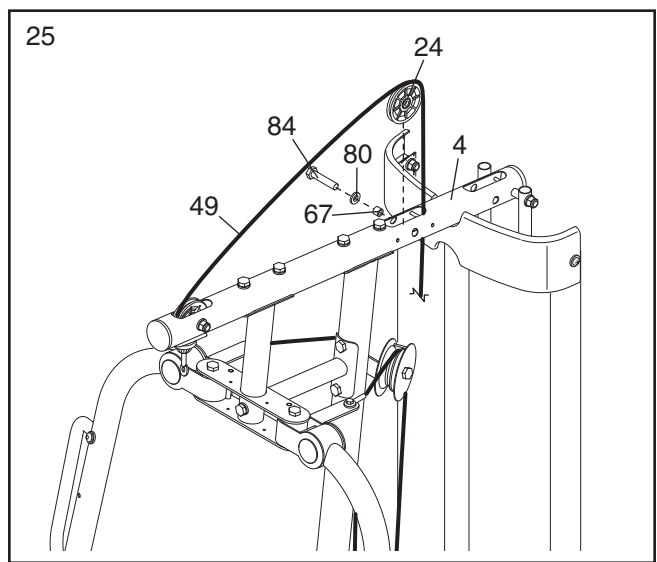

26. Wrap the Lat Cable (49) under a 90mm Pulley (48). Attach the Pulley, a Cable Trap (56), and two Half Guards (55) at the second hole from the top of the two Pulley Plates (60) with an M10 x 50mm Bolt (97) and an M10 Nylon Locknut (77). **Make sure that the Cable Trap and the Half Guards are oriented as shown.**

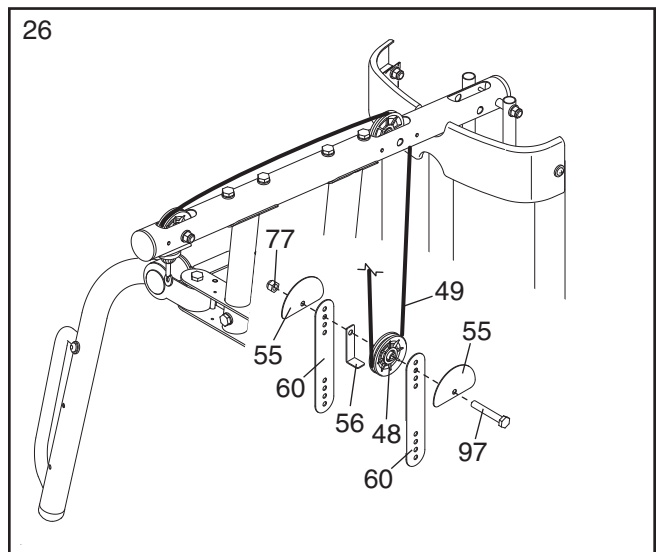

27. Route the Lat Cable (49) up through the Top Frame (4) and wrap the Cable over a Thin Pulley (24). Pull the M10 x 80mm Bolt (84) out of the Top Frame until it is flush with the first Thin Pulley from step 24. **Do not remove the Bolt completely from the Top Frame.**

Hold the second Thin Pulley (24) inside the Top Frame (4) and attach it with the M10 x 80mm Bolt (84), a 19mm Spacer (67), an M10 Washer (80), and an M10 Nylon Locknut (77).

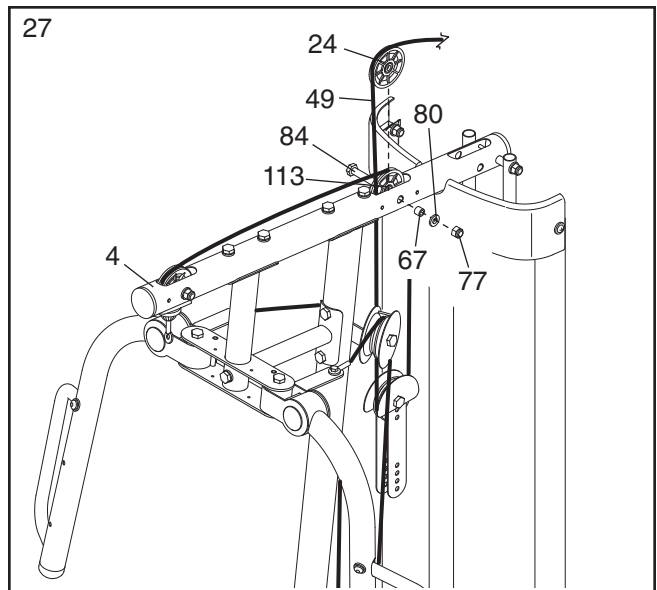

28. Wrap the Lat Cable (49) around a 90mm Pulley (48) and route the Cable down through the Top Frame (4). Attach the Pulley to the Top Frame with an M10 x 80mm Bolt (84), two M10 Washers (80), two 19mm Spacers (67), and an M10 Nylon Locknut (77).

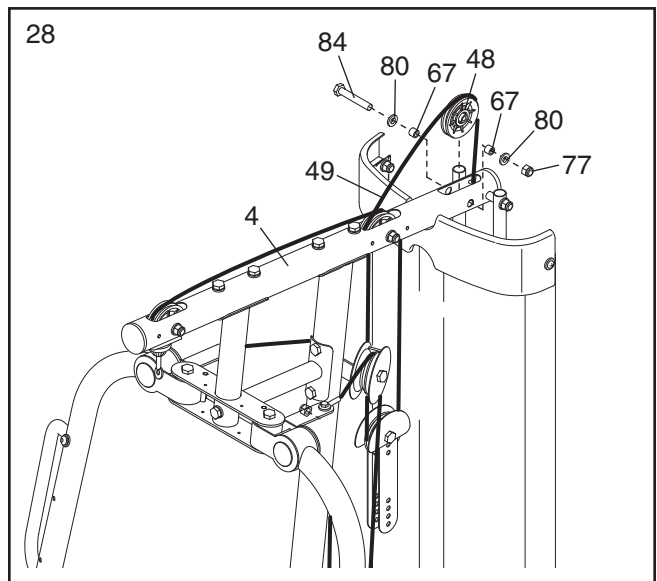

29. Set an M12 Large Washer (98) on top of the Weight Selector (20). Thread the M12 Nut (112) all the way onto the Lat Cable (49).

Thread the Lat Cable (49) into the Weight Selector (20) **two turns**. Tighten the M12 Nut (112) against the M12 Large Washer (98).

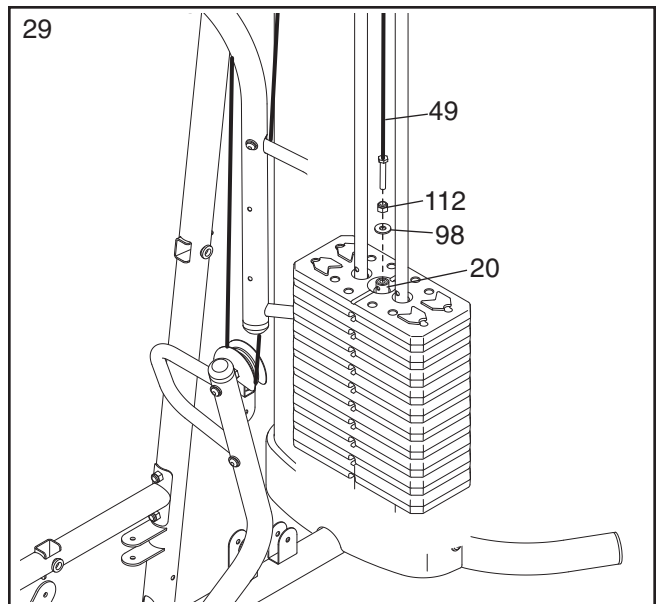

30. **Identify the Leg Lever Cable (51).** Route the Cable through the Leg Lever (12) and the Front Leg (10).

Insert a 90mm Pulley (48) into the Leg Lever (12) from behind it as shown. Attach the 90mm Pulley with an M10 x 65mm Bolt (85), two M10 Washers (80), two 13mm Steel Spacers (109), and an M10 Nylon Locknut (77).

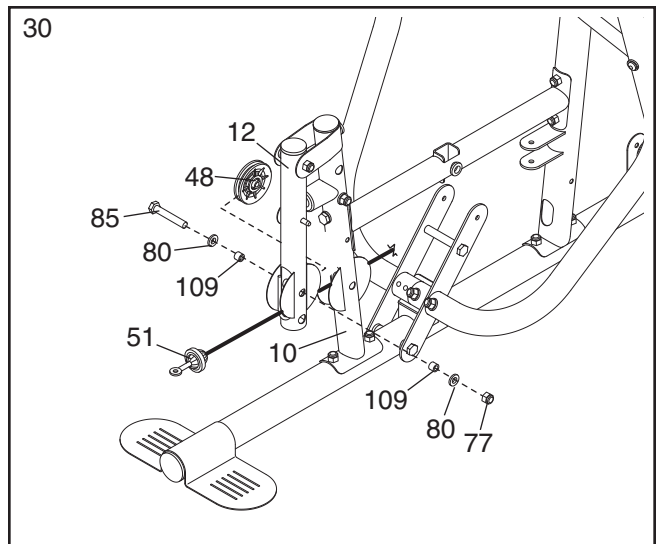

31. Attach a 90mm Pulley (48) to the Front Leg (10) with an M10 x 65mm Bolt (85), two M10 Washers (80), two 13mm Steel Spacers (109), and an M10 Nylon Locknut (77). **Make sure that the Leg Lever Cable (51) is under the Pulley.**

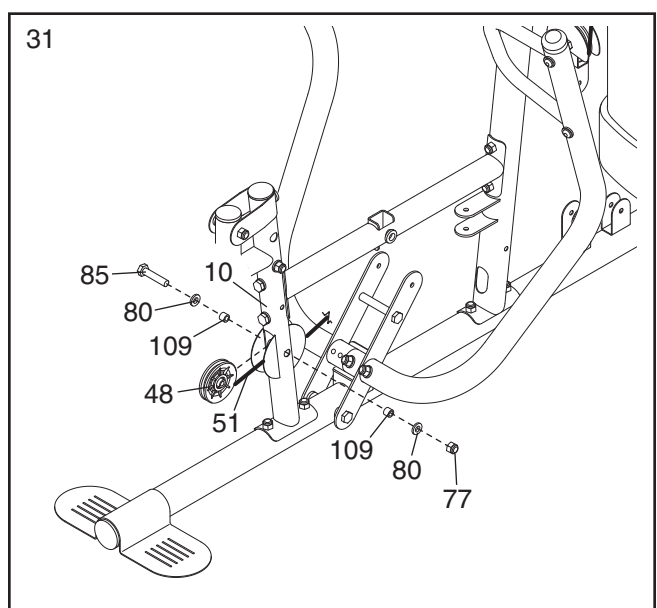

32. Route the Leg Lever Cable (51) under the 89.5mm Spacer (59), through the Upright (2), and under the indicated rod in the Base (1). Wrap the Leg Lever Cable around a 90mm Pulley (48). Attach the Pulley to the Base with an M10 x 45mm Bolt (86), two Half Guards (55), and an M10 Nylon Locknut (77).

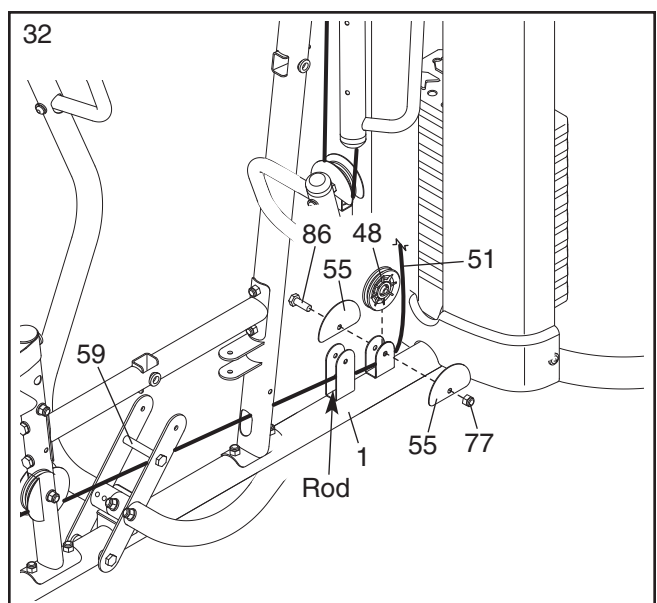

33. Wrap the Leg Lever Cable (51) over a 90mm Pulley (48). Attach the Pulley, a Cable Trap (56), and two Half Guards (55) to the second hole from the bottom of the Pulley Plates (60) with an M10 x 50mm Bolt (97) and an M10 Nylon Locknut (77). **Make sure that the Cable Trap and the Half Guards are oriented as shown.**

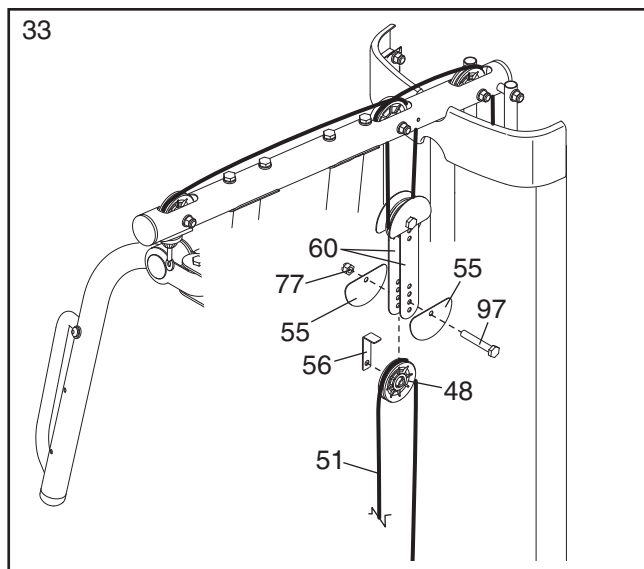

34. Wrap the Leg Lever Cable (51) under a 90mm Pulley (48). Attach the Pulley to the Base (1) with an M10 x 45mm Bolt (86), two Half Guards (55), and an M10 Nylon Locknut (77).

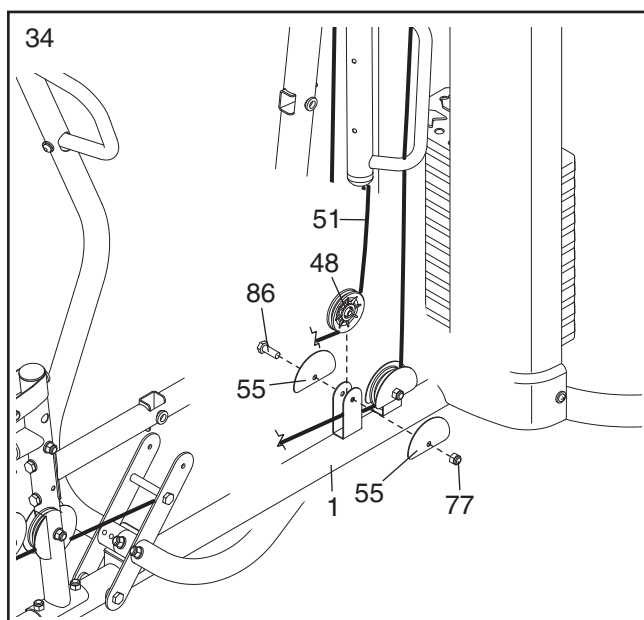

35. Wrap the Leg Lever Cable (51) over a 90mm Pulley (48). Attach the Pulley to the Double "U"-bracket (61) with an M10 x 45mm Bolt (86), two Half Guards (55), and an M10 Nylon Locknut (77).

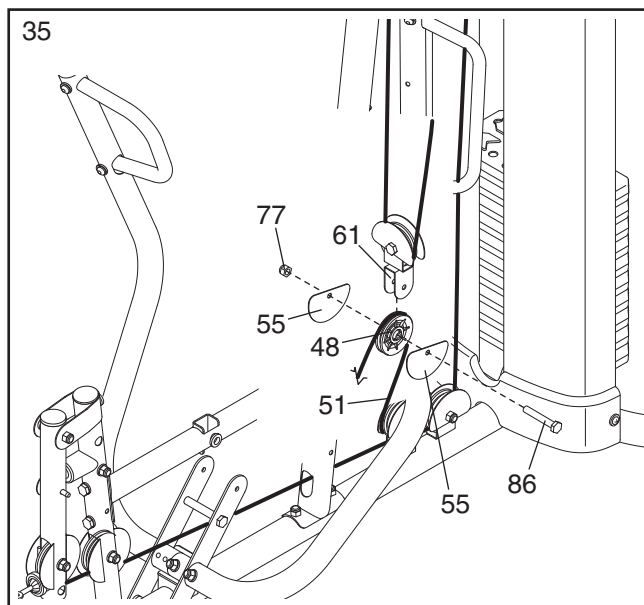

36. Wrap the Leg Lever Cable (51) under a 90mm Pulley (48). Attach the Pulley to the Upright (2) with an M10 x 120mm Bolt (115), two Half Guards (55), an M10 Washer (80), and a Cable Trap (56).

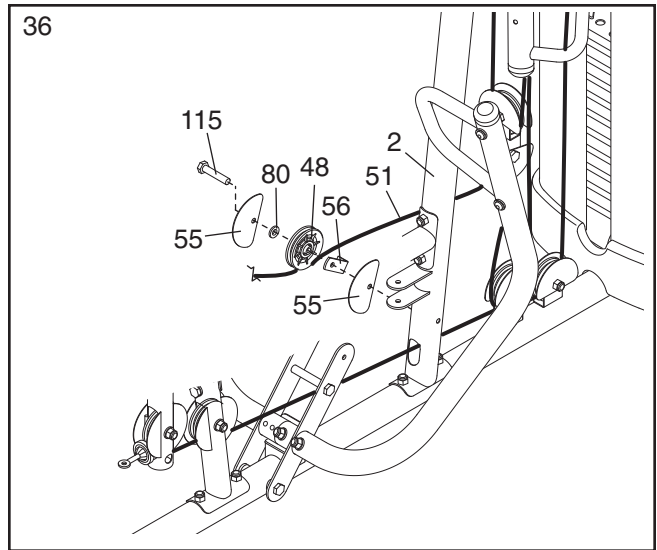

37. Wrap the Leg Lever Cable (51) under a 90mm Pulley (48). Attach the Pulley to the Right Press Arm (16) with an M10 x 50mm Bolt (97), two Half Guards (55), a Cable Trap (56), an M10 Washer (80), and an M10 Nylon Locknut (77). **Make sure that the Cable Trap and the Half Guards are oriented as shown.**

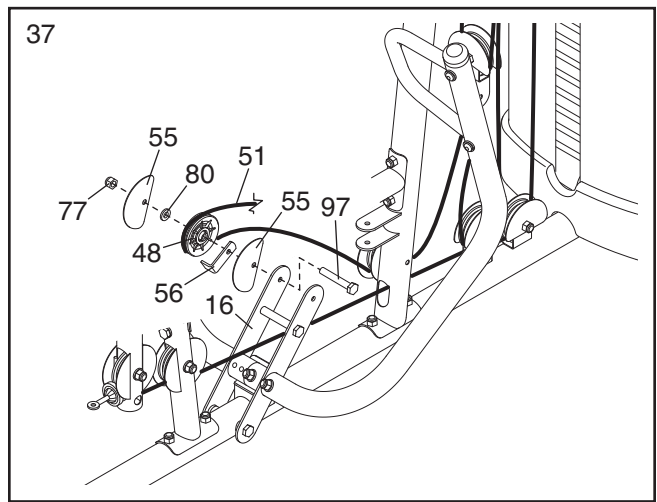

38. Wrap the Leg Lever Cable (51) around a "V"-pulley (47). Attach the Pulley to the Upright (2) with an M10 x 70mm Bolt (113), two Half Guards (55), an M10 Washer (80), a Long Cable Trap (57), and an M10 Nylon Locknut (77). **Make sure that the Cable Trap and the Half Guards are oriented as shown.**

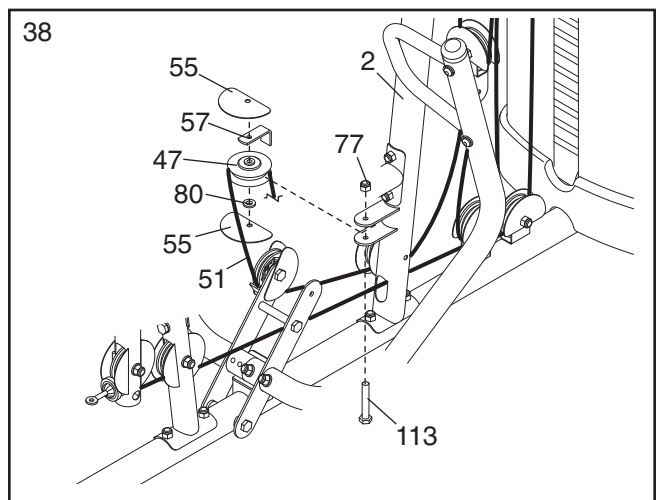

39. Wrap the Leg Lever Cable (51) around a 90mm Pulley (48). Attach the Pulley to the Left Press Arm (15) with an M10 x 50mm Bolt (97), two Half Guards (55), an M10 Washer (80), and a Cable Trap (56). **Make sure that the Cable Trap and the Half Guards are oriented as shown.**

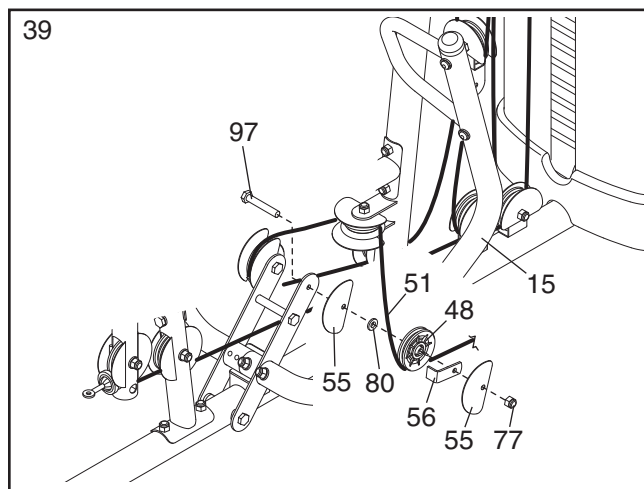

40. Attach the Leg Lever Cable (51) to the Upright (2) with the M10 x 120mm Bolt (115), an M10 Washer (80), a 7mm Spacer (111), and an M10 Nylon Locknut (77). **See the inset drawing. Make sure that the flat edge of the Cable is against the Upright.**

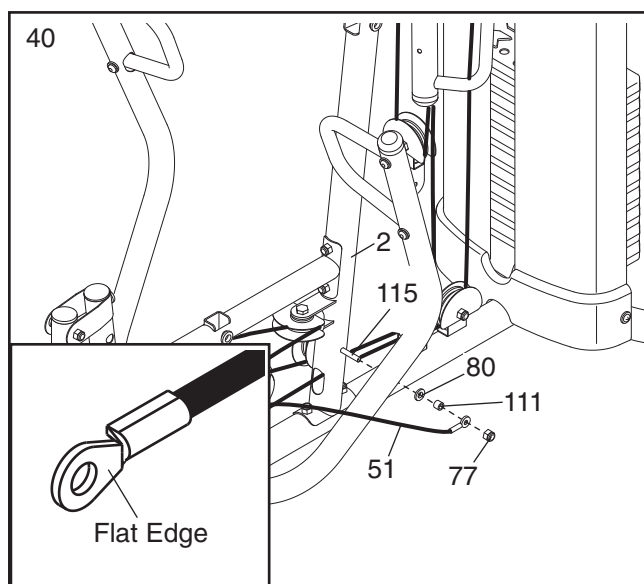

Seat Assembly

41. Attach the Right Butterfly Pad (35) to the Right Butterfly Arm (26) with two M6 x 65mm Button Screws (91) and two M6 Washers (114).

Repeat this step for the Left Butterfly Pad (34).

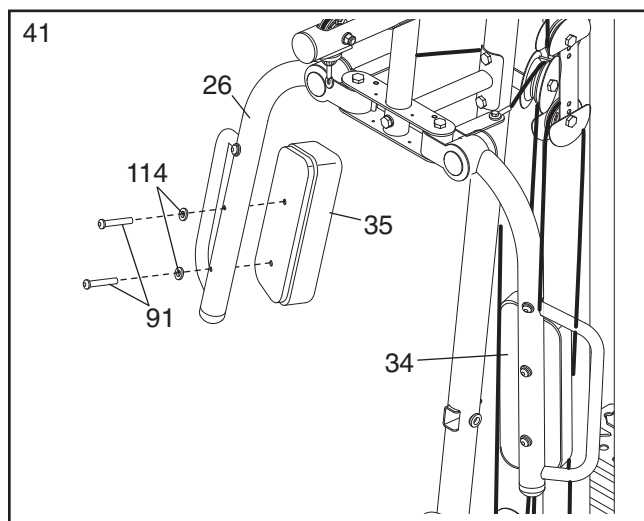

42. Attach the Backrest (31) to the Backrest Frame (7) with two M6 x 20mm Screws (88), an M6 x 38mm Screw (89), and an M6 Washer (114).

Insert the Backrest Frame (7) into the Upright (2) and tighten the Backrest Adjustment Knob (53) into the Upright. **Make sure that the Adjustment Knob passes through one of the holes in the Backrest Frame.**

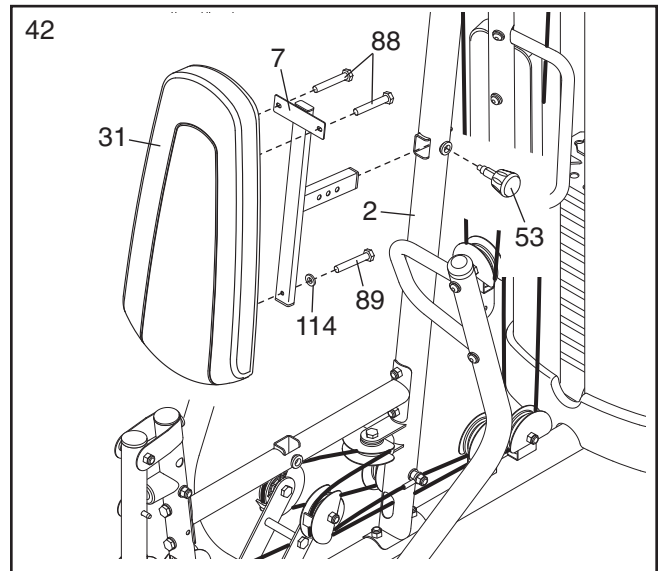

43. Attach the Seat (32) to the Seat Frame (8) with two M6 x 20mm Screws (88), an M6 x 38mm Screw (89), and an M6 Washer (114).

Insert the Seat Frame (8) into the Frame (9). Tighten the Seat Adjustment Knob (52) into the Frame and the Seat Frame. **Make sure that the Adjustment Knob passes through one of the holes in the Seat Frame.**

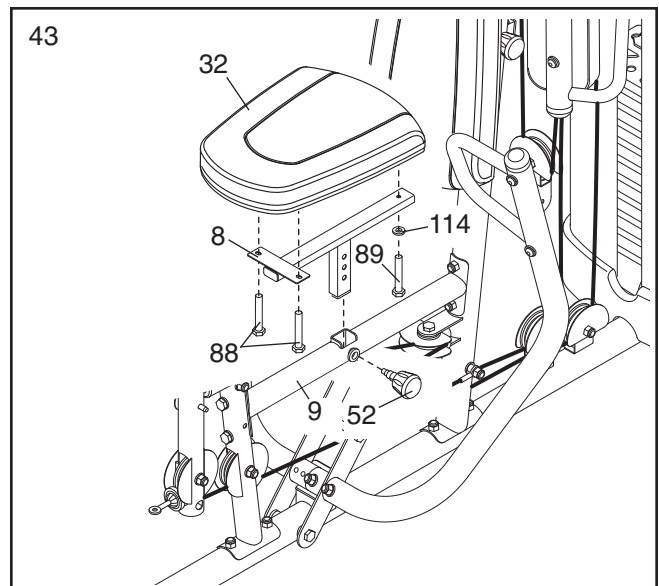

44. Insert a Pad Tube (13) through the indicated hole in the Front Leg (10). Slide a Foam Pad (36) onto each end of the Pad Tube.

Press a Pad Cap (37) into an end of each Foam Pad (36).

Repeat this step for the other Pad Tube (13) and the Leg Lever (12). Note: Lift the Leg Lever Cable (51) when inserting a Pad Tube through through the hole in the bottom of the Leg Lever.

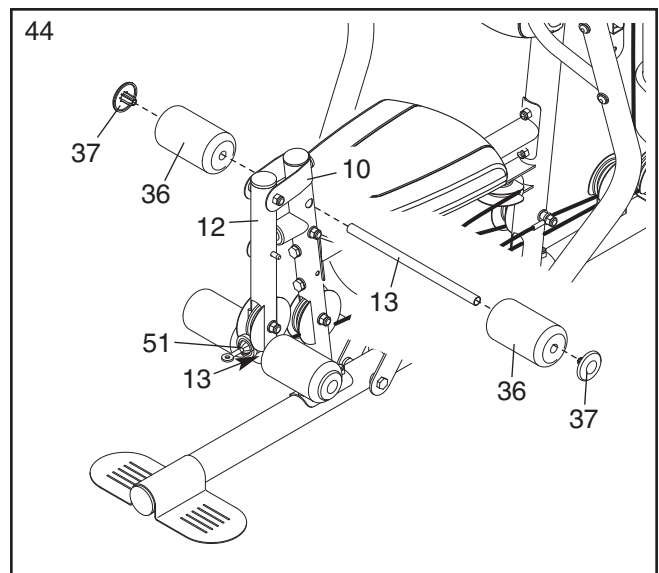

45. Attach the Butterfly Cover (30) to the Butterfly Bracket (5) with four M4 x 12mm Self-tapping Screws (102).

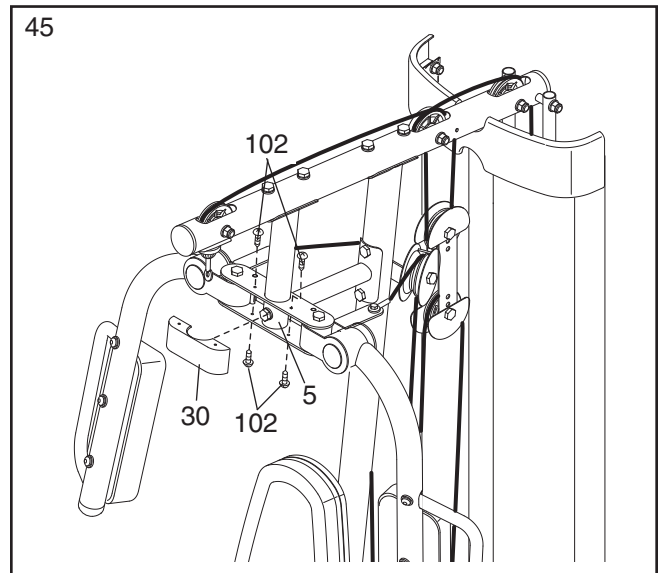

46. Attach the Curl Pad (33) to the Curl Post (11) with two M6 x 20mm Screws (88).

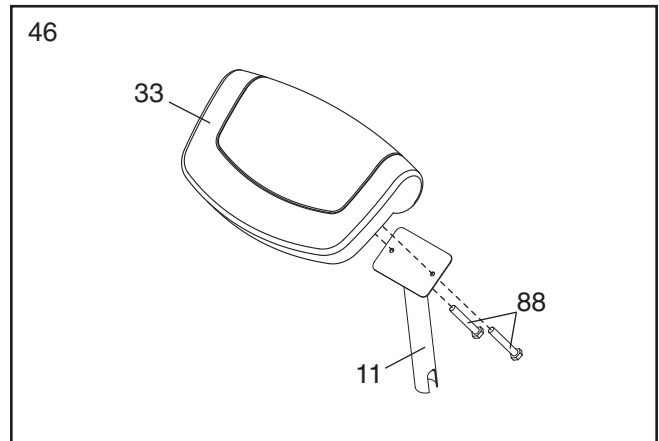

47. Make sure that all parts have been properly tightened. The use of the remaining parts will be explained in ADJUSTMENT, beginning on the following page.

Before using the weight system, pull each cable a few times to make sure that the cables move smoothly over the pulleys. If one of the cables does not move smoothly, find and correct the problem. **IMPORTANT: If the cables are not properly installed, they may be damaged when heavy weight is used. See the CABLE DIAGRAMS on page 28 for proper cable routing. If there is any slack in the cables, you will need to remove the slack by tightening the cables. See MAINTENANCE on page 29.**

ADJUSTMENT

This section explains how to adjust the weight system. Refer to the accompanying exercise guide to see the correct form for each exercise.

Make sure that all parts are properly tightened each time the weight system is used. Replace any worn parts immediately. The weight system can be cleaned with a damp cloth and a mild, non-abrasive detergent. Do not use solvents.

CHANGING THE WEIGHT SETTING

To change the weight setting of the weight stack, insert the Weight Pin (70) under the desired Weight (19). Make sure to insert the Weight Pin until the bent end of the Weight Pin is touching the Weights, and turn the bent end upward. **Note: The weight system works best when at least two Weights are used.**

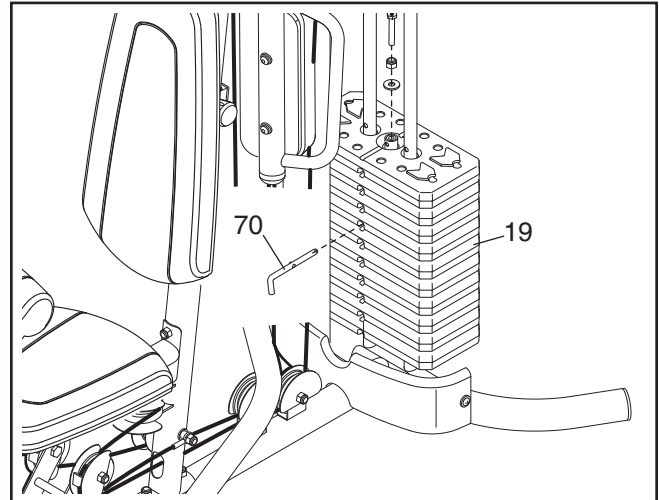

ATTACHING THE ACCESSORIES

To attach the Lat Bar (63) to the Lat Cable (49), attach a Weight Clip (66) to the Lat Cable and the Lat Bar. **Note: For some exercises, you will need to attach the Chain (not shown) to the Weight Clip and use another Weight Clip to attach the Chain to the Lat Bar.**

Attach the other accessories to the weight system in the same way.

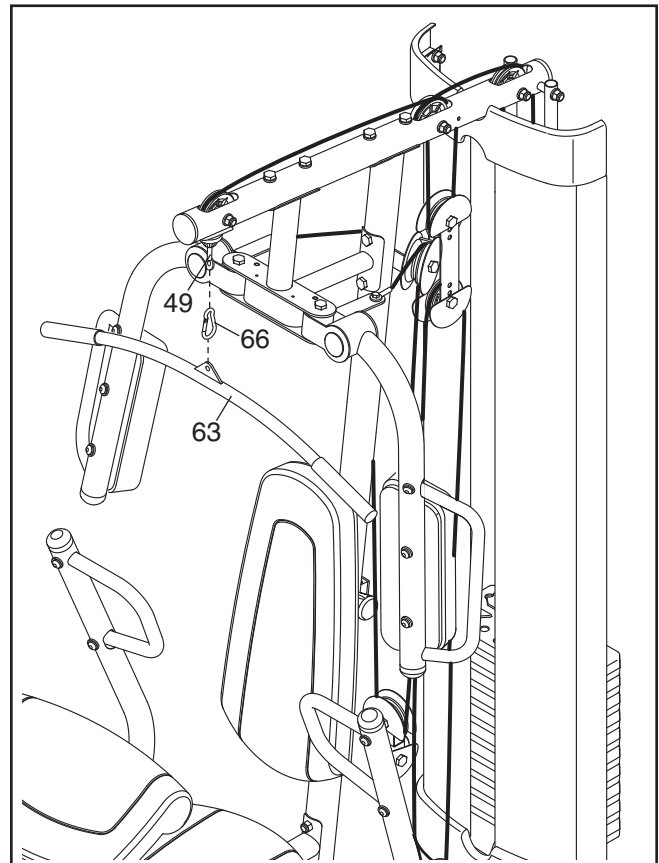

USING THE CURL PAD

To use the Curl Pad (33), remove the indicated 50mm Round Inner Cap (39) and insert the Curl Post (11) into the Front Leg (10). Tighten the Curl Adjustment Knob (58) into the Front Leg. Make sure that the Adjustment Knob passes through a hole in the Curl Post.

When you are performing exercises that do not require the Curl Pad (33), remove the Curl Pad and reinsert the 50mm Round Inner Cap (39) into the Front Leg (10). **You must remove the Curl Pad to use the press arms.**

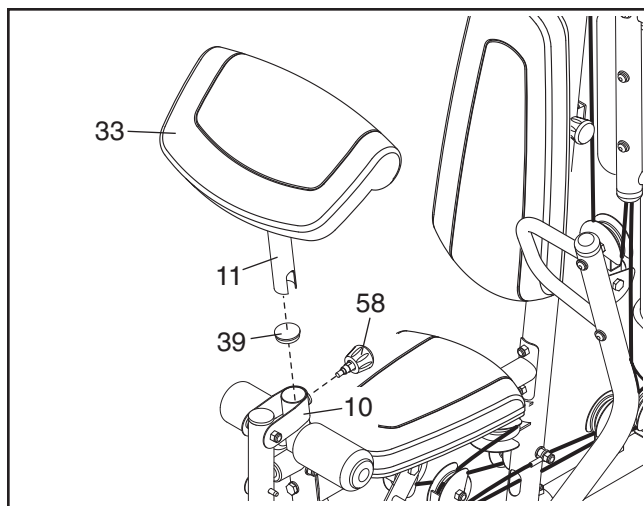

ADJUSTING THE BACKREST

The Backrest (31) can be adjusted to the correct position for each exercise. To adjust the Backrest, first loosen but do not remove the Backrest Adjustment Knob (53) and pull it. Next, move the Backrest in or out of the Upright (2). Insert the Adjustment Knob into the Upright and through the Backrest Frame (not shown). Then, tighten the Adjustment Knob.

The Seat (32) can be adjusted in the same way.

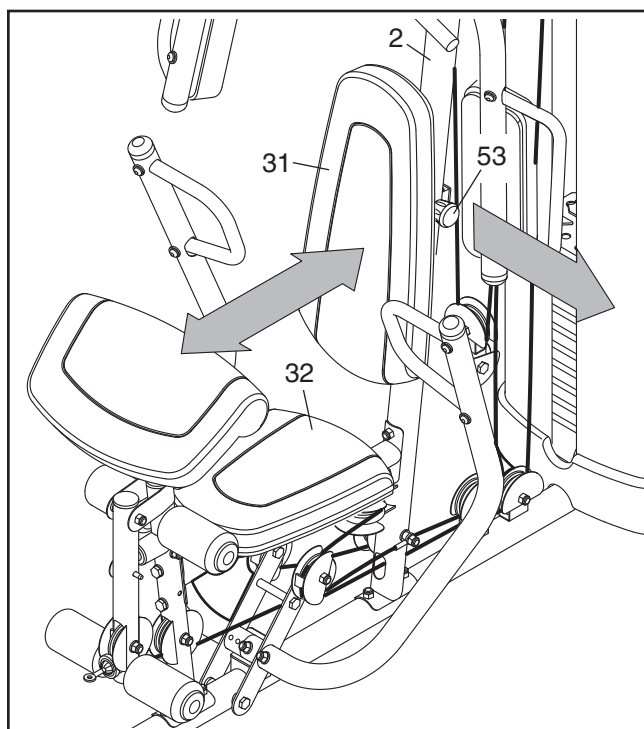

LOCKING THE WEIGHT STACK

To lock the weight stack, insert the Locking Pin (72) through one of the holes in the Weight Guide (18) and secure the Pin with the Lock (73).

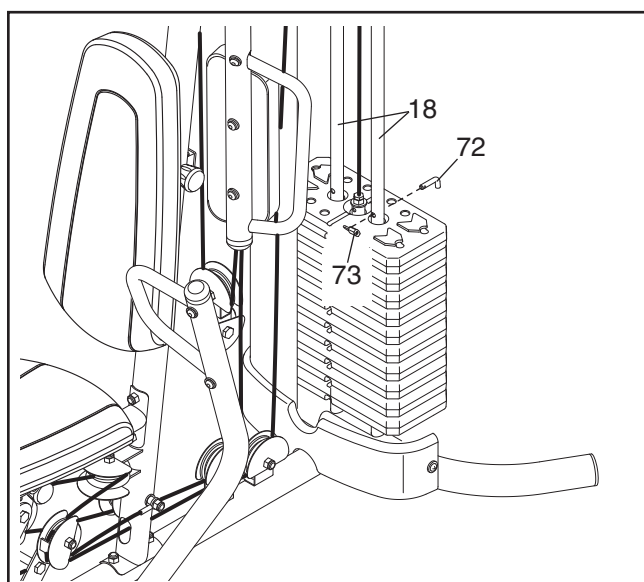

LOCKING THE LEG LEVER

To lock or unlock the Leg Lever, remove the Lock Plate Pin (95) from the Lock Plate (14). Move the Lock Plate to either the position shown on the Front Leg (10) or the indicated hole in the Leg Lever (12). Insert the Lock Pin back through the Lock Plate.

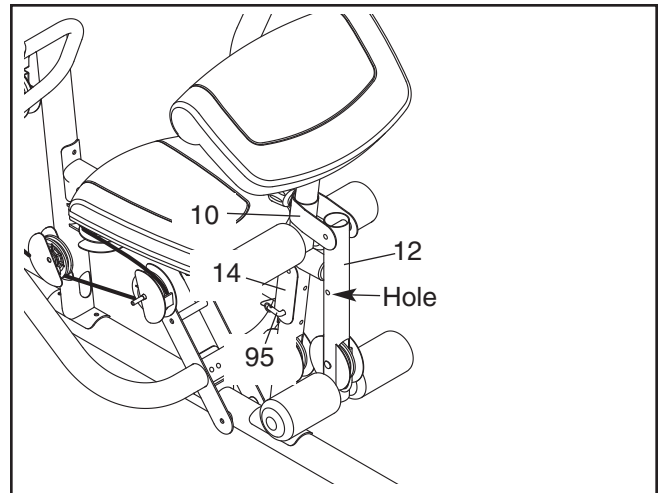

WEIGHT RESISTANCE CHART

The chart below shows the approximate weight resistance at each exercise station. Weight resistance shown for the butterfly arm station is for each arm. **Note: The actual resistance at each station may vary due to differences in individual weights as well as friction between the cables, pulleys, and weight guides.**

WEIGHT	HIGH PULLEY (lbs.)	BUTTERFLY ARM (lbs.)	PRESS ARM (lbs.)	LEG LEVER (lbs.)	LOW PULLEY (lbs.)
1	26	17	46	27	25
2	38	24	63	42	39
3	51	32	76	54	52
4	62	41	90	69	67
5	76	48	104	87	80
6	94	55	121	103	92
7	124	64	138	116	111
8	133	71	153	127	121
9	165	79	172	135	140
10	178	90	195	167	168

Note: 1 lb. = 0.454 kg

CABLE DIAGRAM

The diagram below shows the proper routing of the cables. The numbers show the proper route for that cable. Use the diagram to make sure that the cables, cable traps, and finger guards have been assembled correctly. If the cables are not assembled correctly, the weight system will not function properly and damage may occur. **Make sure that the cable traps do not touch or bind the cables.**

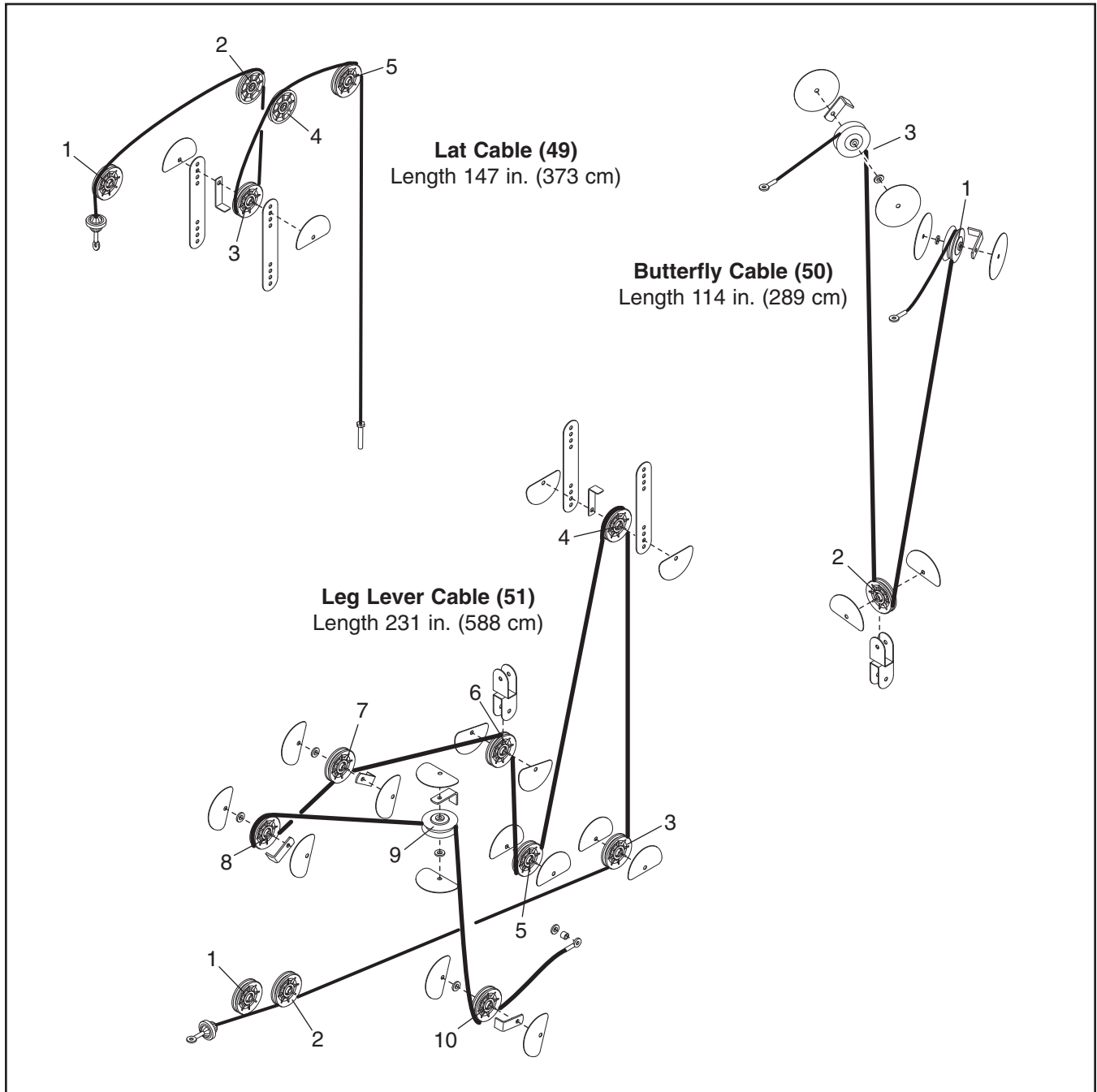

MAINTENANCE

Make sure that all parts are properly tightened each time the weight system is used. Replace any worn parts immediately. The weight system can be cleaned with a damp cloth and a mild, non-abrasive detergent. Do not use solvents.

TIGHTENING THE CABLES

Woven cable, the type of cable used on the weight system, can stretch slightly when it is first used. If there is slack in the cables before resistance is felt, the cables should be tightened. To tighten the cables, first insert the weight pin into the middle of the weight stack. Slack can be removed from these cables several ways:

See drawing 1. Remove the M10 Nylon Locknut (77) and the M10 x 50mm Bolt (97) from the Cable Trap (56), the 90mm Pulley (48), the two Half Guards (55), and the two Pulley Plates (60). Reattach the Pulley, Cable Trap, and Half Guards to the next closer hole to the center of the Pulley Plates. **Make sure that the Cable Trap is oriented to hold the cable in the groove of the Pulley, that the Half Guards are oriented as shown, and that the Cable and Pulley move smoothly.**

See drawing 2. Loosen the M12 Nut (112) on the Lat Cable (49). Tighten the Cable into the Weight Selector (not shown) until the slack is removed from the Cable. Retighten the M12 Nut against the M12 Large Washer (98).

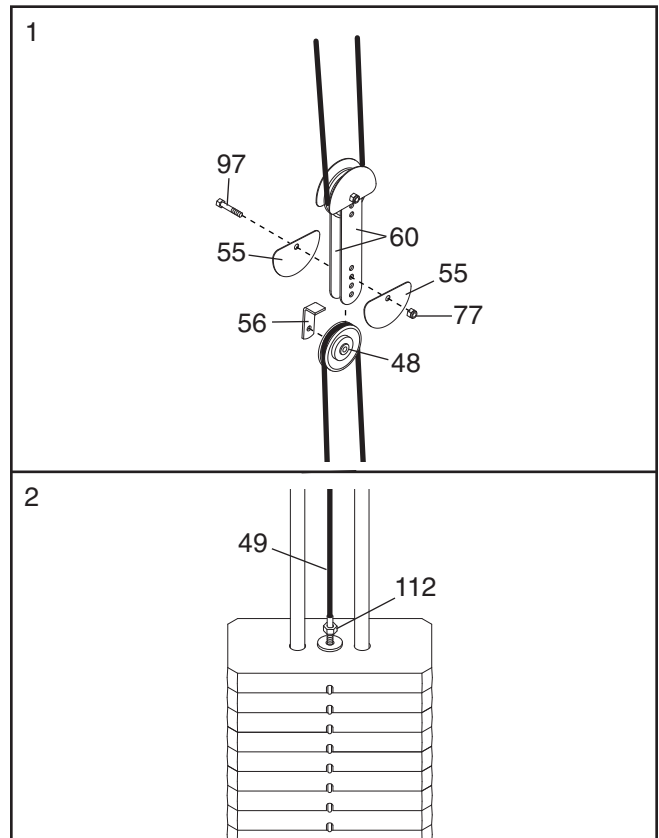

Do not overtighten the cables. If the cables are overtightened, the top weight will be lifted off the weight stack. If a cable tends to slip off the pulleys often, it may have become twisted. Remove the cable and re-install it. If the cables need to be replaced, see the part ordering information on the back cover of this manual.

EXERCISE GUIDELINES

THE FOUR BASIC TYPES OF WORKOUTS

Muscle Building

To increase the size and strength of your muscles, push them close to their maximum capacity. Your muscles will continually adapt and grow as you progressively increase the intensity of your exercise. You can adjust the intensity level of an individual exercise in two ways:

- by changing the amount of resistance used
- by changing the number of repetitions or sets performed. (A “repetition” is one complete cycle of an exercise, such as one sit-up. A “set” is a series of repetitions.)

The proper amount of resistance for each exercise depends upon the individual user. You must gauge your limits and select the amount of resistance that is right for you. Begin with 3 sets of 8 repetitions for each exercise you perform. Rest for 3 minutes after each set. When you can complete 3 sets of 12 repetitions without difficulty, increase the amount of resistance.

Toning

You can tone your muscles by pushing them to a moderate percentage of their capacity. Select a moderate amount of resistance and increase the number of repetitions in each set. Complete as many sets of 15 to 20 repetitions as possible without discomfort. Rest for 1 minute after each set. Work your muscles by completing more sets rather than by using high amounts of resistance.

Weight Loss

To lose weight, use a low amount of resistance and increase the number of repetitions in each set. Exercise for 20 to 30 minutes, resting for a maximum of 30 seconds between sets.

Cross Training

Cross training is an efficient way to get a complete and well-balanced fitness program. An example of a balanced program follows:

- Plan strength training workouts on Monday, Wednesday, and Friday.
- Plan 20 to 30 minutes of aerobic exercise, such as running on a treadmill or riding on an elliptical exerciser or exercise cycle, on Tuesday and Thursday.
- Rest from both strength training and aerobic exercise for at least one full day each week to give your body time to regenerate.

The combination of strength training and aerobic exercise will reshape and strengthen your body, plus develop your heart and lungs.

PERSONALIZING YOUR EXERCISE PROGRAM

Determining the appropriate length of time for each workout, and the numbers of repetitions and sets to complete, is an individual matter. Avoid overdoing it during the first few months of your exercise program. Progress at your own pace and be sensitive to your body’s signals. If you experience pain or dizziness while exercising, stop immediately and cool down. Find out what is wrong before continuing. Remember that adequate rest and a proper diet are important factors in any exercise program.

WARMING UP

Begin each workout with 5 to 10 minutes of stretching and light exercise to warm up. Warming up prepares your body for more strenuous exercise by increasing circulation, raising your body temperature and delivering more oxygen to your muscles.

WORKING OUT

Each workout should include 6 to 10 different exercises. Select exercises for every major muscle group, emphasizing areas that you want to develop most. To give balance and variety to your workouts, vary the exercises from workout to workout.

Schedule your workouts for the time of day when your energy level is the highest. Each workout should be followed by at least one day of rest. Once you find the schedule that is right for you, stick with it.

EXERCISE FORM

Maintaining proper form is an essential part of an effective exercise program. This requires moving through the full range of motion for each exercise, and moving only the appropriate parts of the body. Exercising in an uncontrolled way will leave you feeling exhausted. On the exercise guide accompanying this manual you will find photographs showing the correct form for several exercises, and a list of the muscles affected. See the muscle chart on the next page to find the names of the muscles.

Perform the repetitions in each set smoothly and without pausing. The exertion stage of each repetition should last about half as long as the return stage. Proper breathing is important. Exhale during the exertion stage of each repetition and inhale during the return stroke; never hold your breath.

The repetitions in each set should be performed smoothly and without pausing. The exertion stage of each repetition should last about half as long as the return stage. Proper breathing is important. Exhale during the exertion stage of each repetition and inhale during the return stroke. Never hold your breath.

Rest for a short period of time after each set. The ideal resting periods are:

- Rest for three minutes after each set for a muscle building workout.
- Rest for one minute after each set for a toning workout.
- Rest for 30 seconds after each set for a weight loss workout.

Plan to spend the first couple of weeks familiarizing yourself with the equipment and learning the proper form for each exercise.

COOLING DOWN

End each workout with 5 to 10 minutes of stretching. Include stretches for both your arms and legs. Move slowly as you stretch and do not bounce. Ease into each stretch gradually and go only as far as you can without strain. Stretching at the end of each workout is an effective way to increase flexibility.

STAYING MOTIVATED

For motivation, keep a record of each workout. List the date, the exercises performed, the resistance used, and the numbers of sets and repetitions completed. Record your weight and key body measurements at the end of every month. The key to achieving the greatest results is to make exercise a regular and enjoyable part of your everyday life.

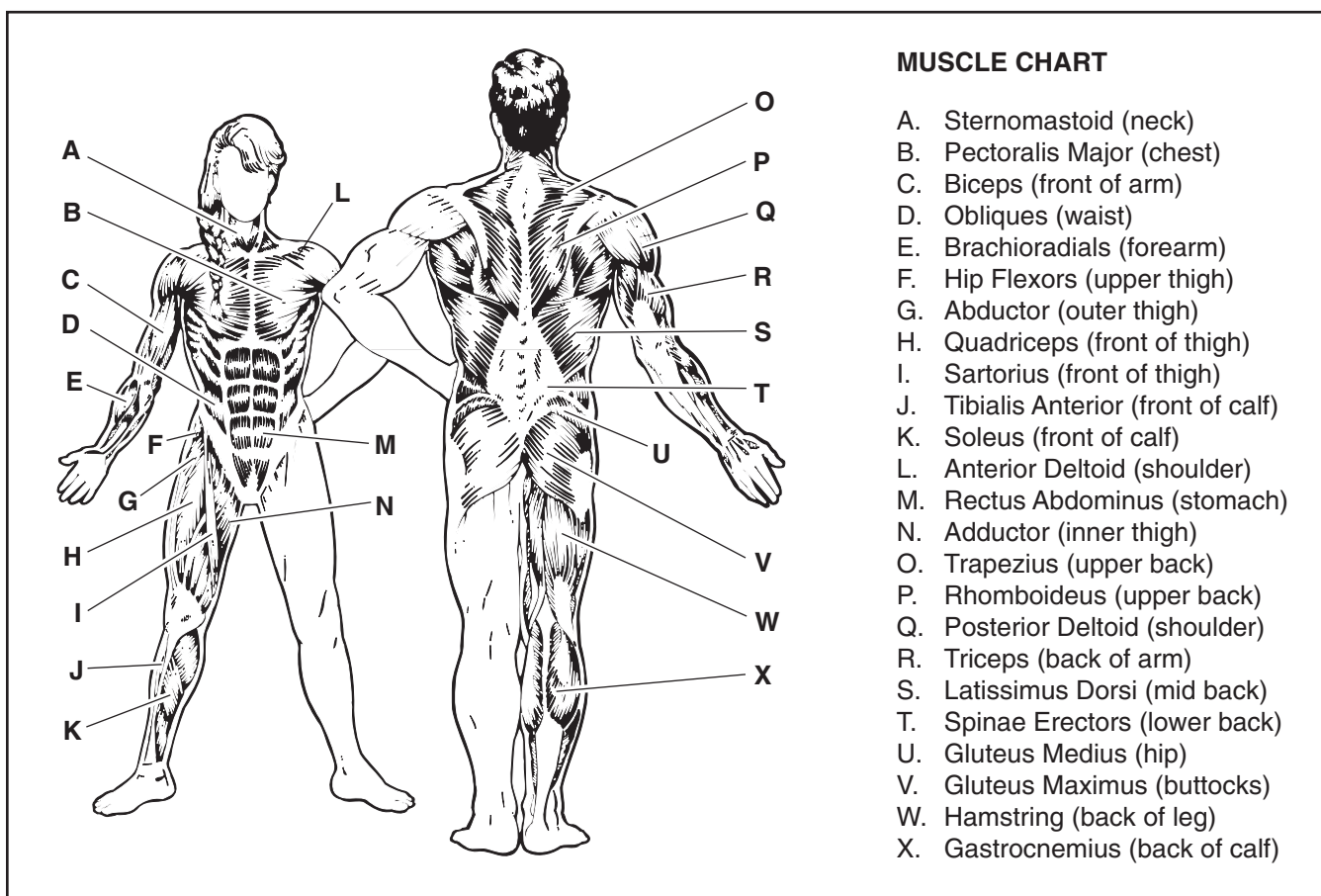

MUSCLE CHART

- A. Sternomastoid (neck)
- B. Pectoralis Major (chest)
- C. Biceps (front of arm)
- D. Obliques (waist)
- E. Brachioradials (forearm)
- F. Hip Flexors (upper thigh)
- G. Abductor (outer thigh)
- H. Quadriceps (front of thigh)
- I. Sartorius (front of thigh)
- J. Tibialis Anterior (front of calf)
- K. Soleus (front of calf)
- L. Anterior Deltoid (shoulder)
- M. Rectus Abdominus (stomach)
- N. Adductor (inner thigh)
- O. Trapezius (upper back)
- P. Rhomboideus (upper back)
- Q. Posterior Deltoid (shoulder)
- R. Triceps (back of arm)
- S. Latissimus Dorsi (mid back)
- T. Spinae Erectors (lower back)
- U. Gluteus Medius (hip)
- V. Gluteus Maximus (buttocks)
- W. Hamstring (back of leg)
- X. Gastrocnemius (back of calf)

PART LIST—Model No. GGSY3058.0

R0408A

Key No.	Qty.	Description	Key No.	Qty.	Description
1	1	Base	51	1	Leg Lever Cable
2	1	Upright	52	1	Seat Adjustment Knob
3	1	Stabilizer	53	1	Backrest Adjustment Knob
4	1	Top Frame	54	4	Guard
5	1	Butterfly Frame	55	20	Half Guard
6	1	Butterfly Frame Brace	56	5	Cable Trap
7	1	Backrest Frame	57	3	Long Cable Trap
8	1	Seat Frame	58	1	Curl Adjustment Knob
9	1	Frame	59	2	89.5mm Spacer
10	1	Front Leg	60	2	Pulley Plate
11	1	Curl Post	61	1	Double "U"-bracket
12	1	Leg Lever	62	1	Ankle Strap
13	2	Pad Tube	63	1	Lat Bar
14	1	Lock Plate	64	2	Hand Grip
15	1	Left Press Arm	65	1	Handle
16	1	Right Press Arm	66	2	Weight Clip
17	2	Press Arm Handle	67	6	19mm Spacer
18	2	Weight Guide	68	4	25mm Bushing
19	10	Weight	69	1	56.5mm Spacer
20	1	Weight Selector	70	1	Weight Pin
21	1	Left Shroud	71	2	Weight Bumper
22	1	Right Shroud	72	1	Lock Pin
23	2	Shroud Cover	73	1	Lock
24	2	Thin Pulley	74	8	16mm Bushing
25	1	Left Butterfly Arm	75	1	Leg Lever Bumper
26	1	Right Butterfly Arm	76	1	Weight Selector Cap
27	2	Butterfly Handle	77	33	M10 Nylon Locknut
28	1	Left Butterfly Bracket	78	18	M8 Nylon Locknut
29	1	Right Butterfly Bracket	79	2	M10 x 60mm Bolt
30	1	Butterfly Cover	80	35	M10 Washer
31	1	Backrest	81	2	M10 x 85mm Bolt
32	1	Seat	82	2	M10 x 75mm Bolt
33	1	Curl Pad	83	5	M8 x 75mm Carriage Bolt
34	1	Left Butterfly Pad	84	5	M10 x 80mm Bolt
35	1	Right Butterfly Pad	85	4	M10 x 65mm Bolt
36	4	Foam Pad	86	4	M10 x 45mm Bolt
37	4	Pad Cap	87	1	M8 x 69mm Shoulder Bolt
38	5	63.5mm Round Inner Cap	88	6	M6 x 20mm Screw
39	3	50mm Round Inner Cap	89	2	M6 x 38mm Screw
40	2	Press Arm Cap	90	2	M8 x 22mm Shoulder Bolt
41	4	40mm x 20mm Inner Cap	91	4	M6 x 65mm Button Screw
42	2	40mm x 25mm Inner Cap	92	2	M10 x 82mm Button Screw
43	2	Butterfly Arm Cap	93	2	M10 x 110mm Bolt
44	2	Bolt Cap	94	4	M6 x 28mm Bolt
45	4	Butterfly Arm Bushing	95	1	Lock Plate Pin
46	4	Butterfly Bracket Bushing	96	4	M10 x 20mm Button Screw
47	3	"V"-pulley	97	4	M10 x 50mm Bolt
48	13	90mm Pulley	98	1	M12 Large Washer
49	1	Lat Cable	99	8	11mm Spacer
50	1	Butterfly Cable	100	8	M8 x 80mm Bolt

Key No.	Qty.	Description	Key No.	Qty.	Description
101	2	M8 x 65mm Bolt	113	1	M10 x 70mm Bolt
102	13	M4 x 12mm Self-tapping Screw	114	14	M6 Washer
103	11	M8 Washer	115	1	M10 x 120mm Bolt
104	9	M4 Washer	116	1	M10 x 61mm Bolt Set
105	2	M10 Large Washer	117	1	Chain
106	6	M10 x 65mm Button Bolt	118	1	M10 x 75mm Button Screw
107	4	M6 Nylon Locknut	119	2	38mm Round Inner Cap
108	2	21mm Steel Spacer	*	–	User's Manual
109	8	13mm Steel Spacer	*	–	Exercise Guide
110	9	M4 x 16mm Self-tapping Screw	*	–	Hex Key
111	1	7mm Spacer	*	–	Grease Packet
112	1	M12 Nut			

Note: Specifications are subject to change without notice. See the back cover of this manual for information about ordering replacement parts. *These parts are not illustrated.

EXPLODED DRAWING A—Model No. GGSY3058.0

R0408A

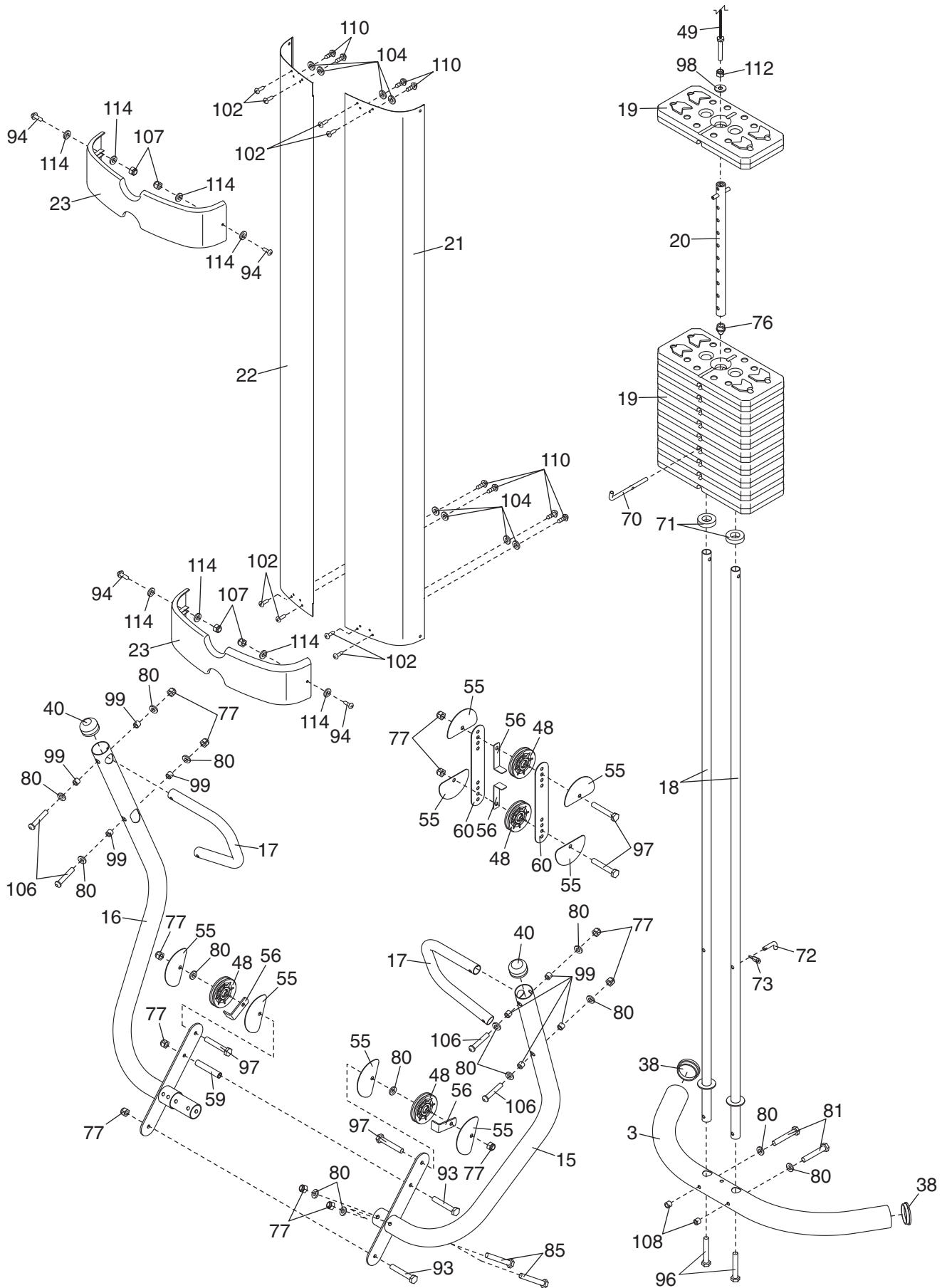

EXPLODED DRAWING B—Model No. GGSY3058.0

R0408A

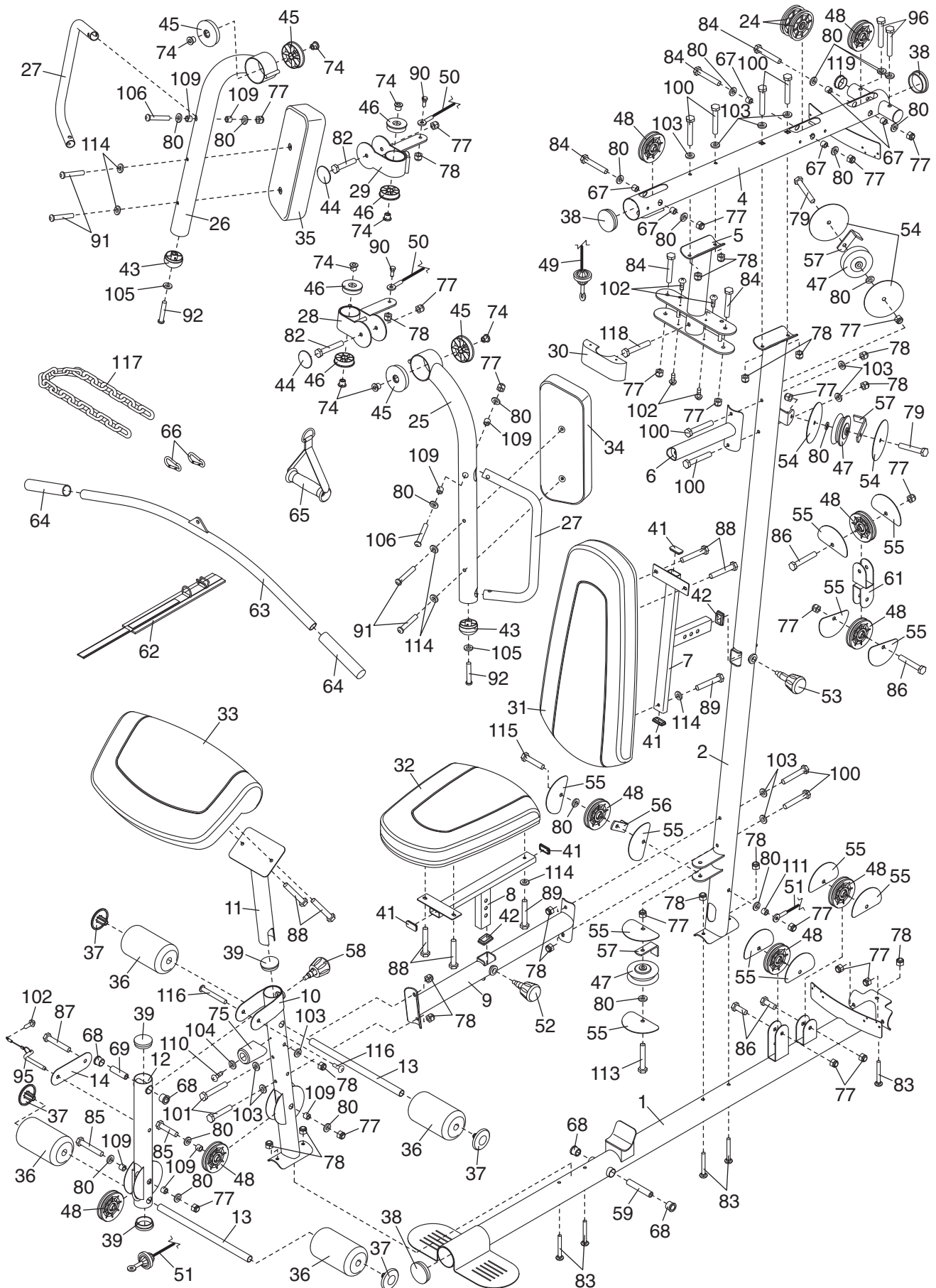

ORDERING REPLACEMENT PARTS

To order replacement parts, please see the front cover of this manual. To help us assist you, be prepared to provide the following information when contacting us:

- the model number and serial number of the product (see the front cover of this manual)
- the name of the product (see the front cover of this manual)
- the key number and description of the replacement part(s) (see the PART LIST and the EXPLODED DRAWING near the end of this manual)

LIMITED WARRANTY

ICON Health & Fitness, Inc. (ICON) warrants this product to be free from defects in workmanship and material, under normal use and service conditions, for a period of ninety (90) days from the date of purchase. This warranty extends only to the original purchaser. ICON's obligation under this warranty is limited to replacing or repairing, at ICON's option, the product through one of its authorized service centers. All repairs for which warranty claims are made must be preauthorized by ICON. If the product is shipped to a service center, freight charges to and from the service center will be the customer's responsibility. For in-home service, the customer will be responsible for a minimal trip charge. This warranty does not extend to any product or damage to a product caused by or attributable to freight damage, abuse, misuse, improper or abnormal usage or repairs not provided by an ICON authorized service center; products used for commercial or rental purposes; or products used as store display models. No other warranty beyond that specifically set forth above is authorized by ICON.

ICON is not responsible or liable for indirect, special or consequential damages arising out of or in connection with the use or performance of the product or damages with respect to any economic loss, loss of property, loss of revenues or profits, loss of enjoyment or use, costs of removal or installation or other consequential damages of whatsoever nature. Some states do not allow the exclusion or limitation of incidental or consequential damages. Accordingly, the above limitation may not apply to you.

The warranty extended hereunder is in lieu of any and all other warranties and any implied warranties of merchantability or fitness for a particular purpose is limited in its scope and duration to the terms set forth herein. Some states do not allow limitations on how long an implied warranty lasts. Accordingly, the above limitation may not apply to you.

This warranty gives you specific legal rights. You may also have other rights which vary from state to state.

ICON HEALTH & FITNESS, INC., 1500 S. 1000 W., LOGAN, UT 84321-9813